



## I-7530A-MR-FD

Modbus RTU to CAN converter

### Features

- Fully compatible with ISO 11898-2 standard
- Support CAN bus acceptance filter configuration
- Built-in jumper to select 120Ω terminal resistor
- Provide the transparent communication between the RS-232/485/422 devices via CAN bus (Pair-connection mode)
- In Modbus Slave mode, supports function code 0x03, 0x04, 0x06, and 0x10
- Support Modbus Master function
- Support CAN FD



### Introduction

I-7530A-MR-FD supports Modbus RTU protocol on RS-232/422/485 port, it is a Modbus RTU to CAN converter, it supports CAN2.0A/2.0B and CAN FD, and provides user-defined CAN Bus communication baud rate (arbitration field: 10Kbps to 1Mbps, CAN FD data field: 100Kbps to 10Mbps).

And with the special designed firmware, beside normal received CAN message buffer, it offers special memory space to save up to 100 kinds of CAN messages which are urgent and must be processed immediately. The feature helps the PLC, HMI and SCADA to use Modbus RTU function code 3,4,16 to access CAN devices in an easy way.

#### Modbus RTU Slave/CAN FD Master Mode

In Modbus RTU mode, it allows a Modbus RTU master to communicate with CAN devices on a CAN network. The following figure shows the application architecture of this mode.



#### Modbus RTU Master/CAN FD Slave Mode

In the Modbus Master mode, it allows many Modbus RTU slaves to communicate with CAN devices on a CAN network. The following figure shows the application architecture in this mode.



#### Pair-Connection Mode

In pair-connection mode, this module provides the pair connection and transparent communication between the RS-232/485/422 devices via CAN bus. The application architecture may be as follows.



• **UART Switch Mode**

In UART Switch mode, the I-7530A-MR-FD can convert CAN messages to UART ASCII or convert UART ASCII to CAN messages

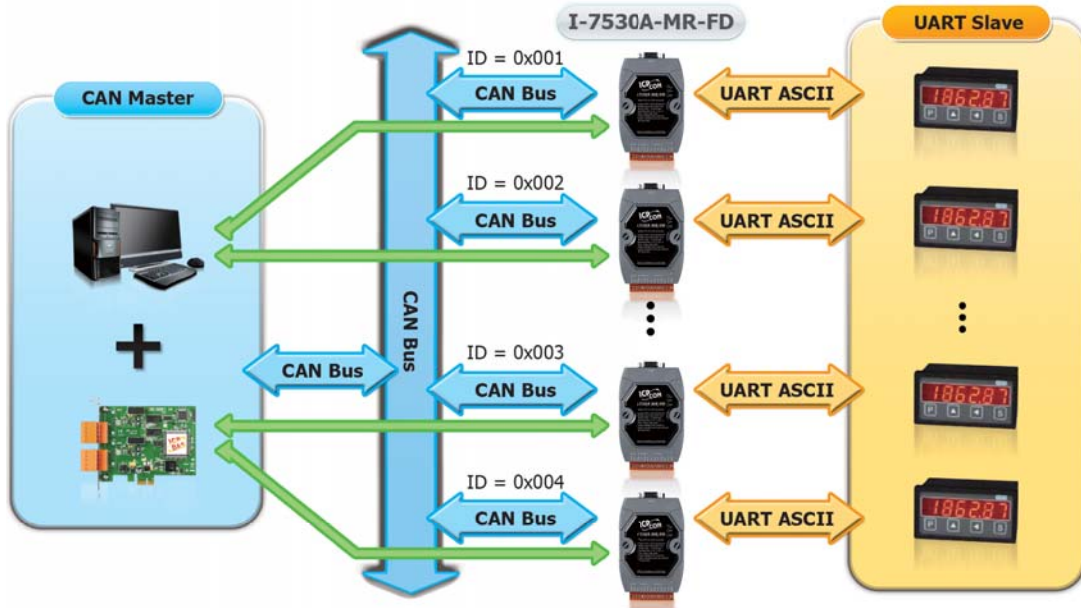

■ **Pin Assignments**

Pin	Description
1	Not Connect
2	CAN Low
3	CAN Ground
4	Not Connect
5	Not Connect
6	CAN Ground
7	CAN High
8	Not Connect
9	Not Connect

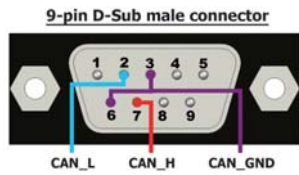

Pin	Description
1	RS-485 DATA+
2	RS-485 DATA-
3	No use
4	RS-422 TxD+
5	RS-422 TxD-
6	RS-422 RxD+
7	RS-422 RxD-
8	No use
9	RS-232 RXD
10	RS-232 TXD
11	RS-232 GND
12	No use
13	+Vs(+10 ~ +30 VDC)
14	GND

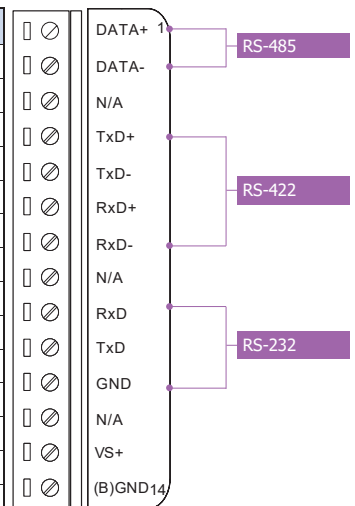

■ **Internal I/O Structure**

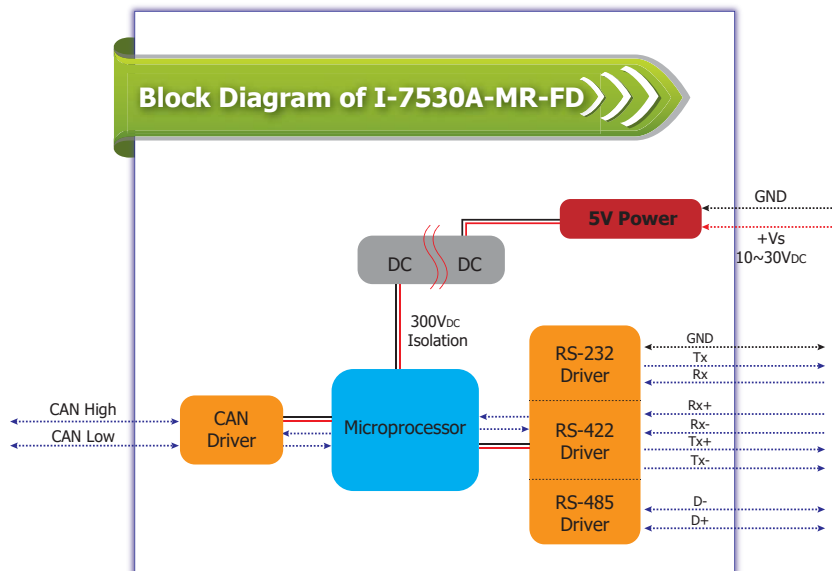

## Wire Connections

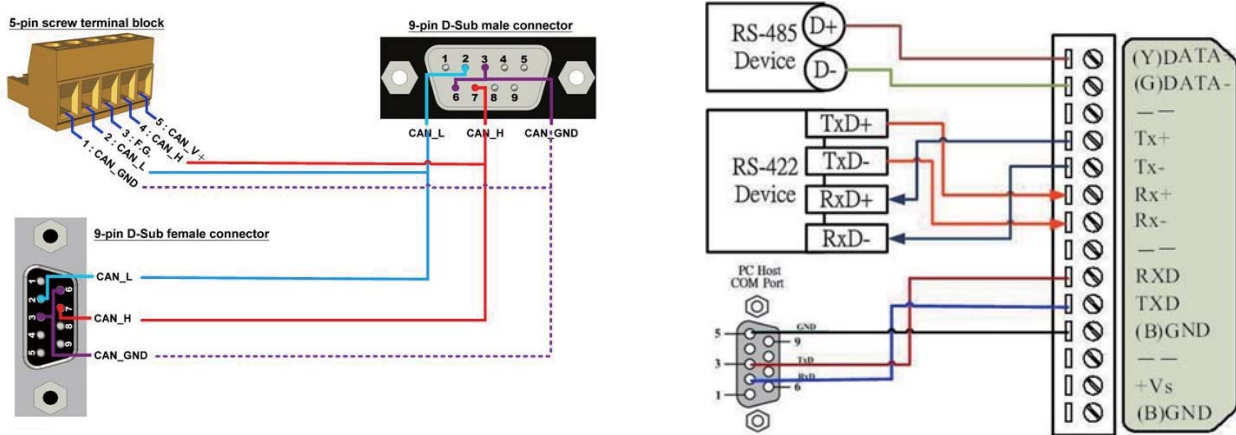

## Specifications

CAN Interface	
Transceiver	TI TCAN1042HG
Channel Number	1
Pin Assignment	C.I.A. DS-102 (CAN_H=7, CAN_L=2)
Connector	9-pin male D-Sub (CAN_L, CAN_H, N/A for others)
Transmission Speed	CAN bit rates: 10 ~ 1000 kbps, CAN FD bit rates for data field: 100 ~ 10000 kbps
Terminal Resistor	Selectable 120Ω terminal resistor by jumper
Protection	33000 VDC for DC-to-DC, 2500Vrms for photo-couple
Specification	ISO 11898-2, CAN 2.0 A/B and FD
CAN Filter Configuration	Selectable via Utility tool
Receive Buffer	64 data frames
UART Interface	
Connector	14-pin terminal connector
COM	RS-232: TxD, RxD, GND; RS-422: TxD+, TxD-, RxD+, RxD-; RS-485: DATA+, DATA-
Baud rate(bps)	300, 600, 1200, 2400, 4800, 9600, 19200, 38400, 57600, 115200, 230400
Protection	3000VDC power protection and 2500Vrms photo-couple isolation on UART side
LED Indicators/Display	
System LED Indicator	1 x Power, 1 x CAN status, 1 x UART status
Power	
Power supply	+10 ~ +30 VDC
Power Consumption	1.5W
Mechanism	
Installation	DIN-Rail
Casing	Plastic
Dimensions	72mm x 118mm x 35mm (W x L x H)
Environment	
Operating Temp.	-25°C to 75°C
Storage Temp.	-30°C to 80°C
Humidity	10~90% non-condensing

## ■ Dimensions (Units: mm)

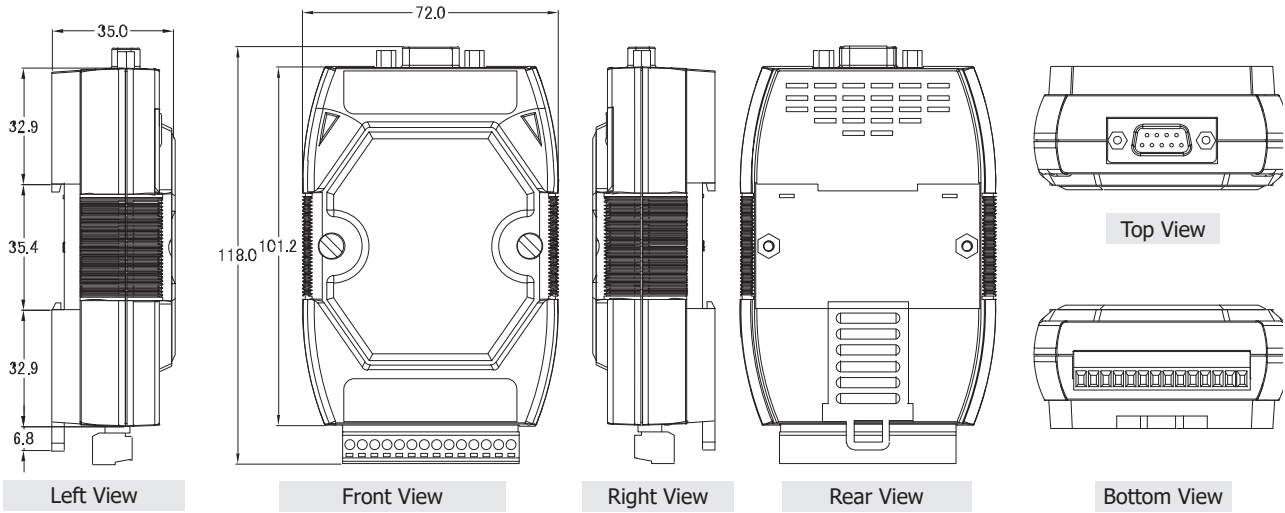

## ■ Ordering Information

<b>I-7530A-MR-FD</b>	Modbus RTU to CAN converter (RoHS)
----------------------	------------------------------------