

Datasheet

InnoAGE™

2.5" SATA SSD 3TI7

- The World's first hybrid SSD with an Azure Sphere inside
- End-to-end security from edge to cloud
- Hardware level allows easy and simple development
- Supports out-of-band network management and diverse platforms
- Supports wireless 2.4/5GHz dual-band 802.11 a/b/g/n Wi-Fi
- Supports Ethernet

Introduction

The InnoAGE™ SSD comes with a Microsoft Azure Sphere inside, and is further integrated with Innodisk's customized firmware, software, and hardware technology. This new solution enables multifunctional management: smart data analysis and updates, data security, and remote control through the cloud, while benefitting from the power of the Azure Sphere to guarantee secured communications between the SSD and the cloud.

The InnoAGE™ SSD delivers an easy-to-use interface with its customized cloud management platform. In technical terms, the Innodisk-developed firmware receives commands from the Azure Sphere via a second connection to Azure. Therefore, it is able to execute SSD debugging messages as well as monitor read/write behavior patterns to increase the storage device's lifespan. Most importantly, system operators can quickly revert to the default settings from the cloud-based dashboard in the case of a device or system crash.

In other words, the InnoAGE™ SSD is designed for both in-band and out-of-band network management, providing full recovery even when the operating system has crashed or is severely impaired to the extent that in-band management would be of little help.

innodisk

ICP Electronics
Australia Pty Ltd

TEL: 02 9457 6011
sales@icp-australia.com.au
www.icp-australia.com.au



Proudly Australian-Owned Since 1999

Contact us for more information about the InnoAGE 2.5" SATA SSD 3TI7.

Innodisk is a service-driven provider of industrial embedded flash and DRAM storage products and technologies, with a focus on the industrial/embedded, aerospace and defense, and cloud computing industries.



Specifications

Interface	SATA III
Flash Type	3D TLC
Capacity	64GB~1TB
Flash Endurance	3,000 P/E cycles
Max. Channels	4
Sequential R/W (MB/sec, max.)*	560 / 330 MB/s
4KB Random (QD32) R/W (IOPS)**	85,000/70,000
Max. Power Consumption	3.6W
Thermal Sensor	✓
ATA Security	✓
S.M.A.R.T.	✓
Dimension (WxLxH)	69.85 X 100.00 X 7.00 mm
Environment	Vibration: 20G @7~2000Hz Shock: 1500G @ 0.5ms Storage Temperature: -55°C to +95°C MTBF: 3 million hours
* Performance based on CrystalDiskMark 5.01 with file size 1000MB	

Headquarters (Taiwan)

5F., No.237, Sec. 1, Datong Rd., Xizhi Dist., New Taipei City, Taiwan (R.O.C.)

Tel: +886-2-77033000

Email: sales@innodisk.com

Branch Offices:

USA

usasales@innodisk.com

+1-510-770-9421

Europe

esusales@innodisk.com

+31-40-3045-400

Japan

jpsales@innodisk.com

+81-3-6667-0161

China

sales_cn@innodisk.com

+86-755-21673689

www.innodisk.com

© 2020 Innodisk Corporation.

All right reserved. Specifications are subject to change without prior notice.

20200416

Quick Erase	Security Erase	Destroy	Recovery	iAnalyzer	S.M.A.R.T.
V	V	V	V	V	V
iData Guard	iPower Guard	ATA Security	TRIM	256-bit AES	
V	V	V	V	V	

Ordering Information

Capacity	Standard Temperature (0°C~70°C)	Industrial Temperature (-40°C~85°C)
64GB	DTS25-64GDK1EC*DFXXG	DTS25-64GDK1EW*DFXXG
128GB	DTS25-A28DK1EC*QFXXG	DTS25-A28DK1EW*QFXXG
256GB	DTS25-B56DK1EC*QFXXG	DTS25-B56DK1EW*QFXXG
512GB	DTS25-C12DK1EC*QFXXG	DTS25-C12DK1EW*QFXXG
1TB	DTS25-01TDK1EC*QFXXG	DTS25-01TDK1EW*QFXXG
Note	XXG: 10G-50G *1: with Ethernet daughter board; 2: with Wi-Fi antenna	

innodisk

ICP Electronics
Australia Pty Ltd

TEL: 02 9457 6011
sales@icp-australia.com.au
www.icp-australia.com.au



Proudly Australian-Owned Since 1999

Edge to Cloud System Architecture

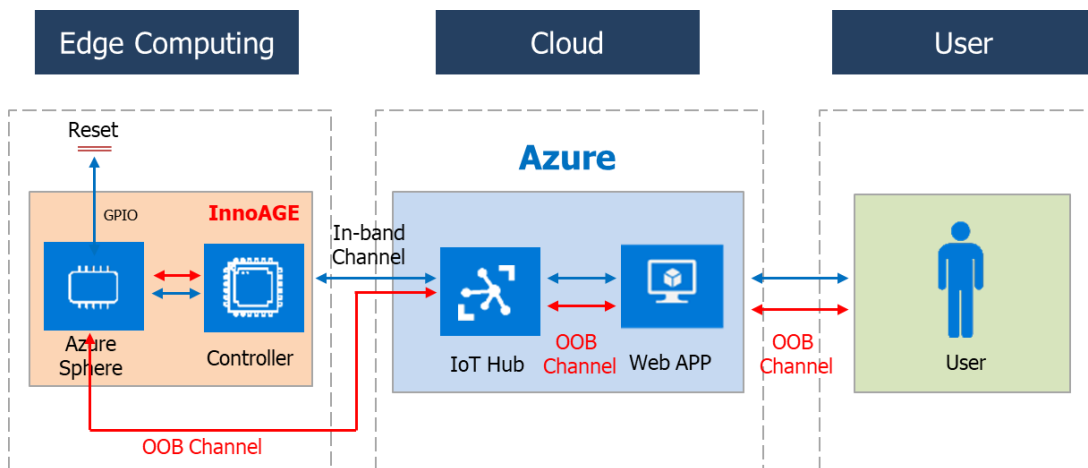

InnoAGE 2.5" SATA SSD External Pin Definition

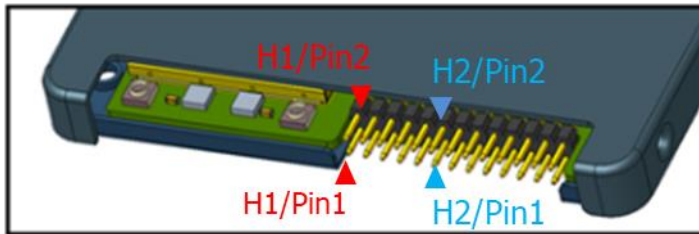

Pin Header 1 Recovery, Reset and External Reserved GPIO

PC_RST	Recovery	GPIO 66	GPIO 68	GPIO 0
H1/Pin 1	H1/Pin 3	H1/Pin 5	H1/Pin 7	H1/Pin 9
H1/Pin 2	H1/Pin 4	H1/Pin 6	H1/Pin 8	H1/Pin 10
GND	GND	GND	GND	GND

Pin	Function	Direction	Notification
1	RC_RST*	O	Active low
	GPIO	I/O	Bi-direction, function programmable
3	Recovery*	I	Active low
	GPIO	I/O	Interrupt-capable and bi-direction, function programmable
5	GPIO	I/O	Bi-direction, function programmable
	TX	O	TX of UART, pair with pin 7
7	GPIO	I/O	Bi-direction, function programmable
	RX	I	RX of UART, pair with pin 5
9	GPIO	I/O	Interrupt-capable and bi-direction, function programmable
	PWM	O	PWM control, frequency/duty TBD
2/4/6/8/10	GND		System GND

* Default setting function
 V_O range: $-0.28 < V_{OL} < 0.4$; $2.4 < V_{OH} < 3.63$ (V)
 V_I range: $-0.28 < V_{IL} < 0.28$; $2.0 < V_{IH} < 3.63$ (V)

Pin Header 2

SPI to Ethernet

INT	MISO	CLK	RST	GND
H2/Pin 1	H2/Pin 3	H2/Pin 5	H2/Pin 7	H2/Pin 9
H2/Pin 2	H2/Pin 4	H2/Pin 6	H2/Pin 8	H2/Pin 10
NC	NC	MOSI	CS	3.3V

Pin	Function	Direction	Notification
1	INT*	I	Interrupt-capable GPIO
	PWM	O	PWM control, frequency/duty TBD
	GPIO	I/O	Bi-direction, function programmable
3	MISO*	I	MISO of SPI interface, pair with pin 5/6/8
	DATA	I/O	CLK of I2C interface, pair with pin5
	RX	I	RX of UART, pair with pin 5/6/8
	GPIO	I/O	Bi-direction, function programmable
5	CLK*	O	CLK of SPI interface, pair with pin 3/6/8
	TX	O	TX of UART, pair with pin 3/6/8
	GPIO	I/O	Bi-direction, function programmable
6	MOSI*	O	MOSI of SPI interface, pair with pin 3/5/8
	CLK	I/O	CLK of I2C interface, pair with pin 3
	RTS	O	RTS of UART, pair with pin 3/5/8
	GPIO	I/O	Bi-direction, function programmable
7	RST	I	SSD module reset pin, active low
8	CS*	O	CS of SPI interface, pair with pin 3/5/6
	CTS	I	CST of UART, pair with pin 3/5/6
	GPIO	I/O	Bi-direction, function programmable
10	3V3		System power 3.3V
9	GND		System GND
2/4	NC		No internal connection

* Default setting function
 V_O range: $-0.28 < V_{OL} < 0.4$; $2.4 < V_{OH} < 3.63$ (V)
 V_I range: $-0.28 < V_{IL} < 0.28$; $2.0 < V_{IH} < 3.63$ (V)

Mechanism Design

1. InnoAGE 2.5" SATA SSD

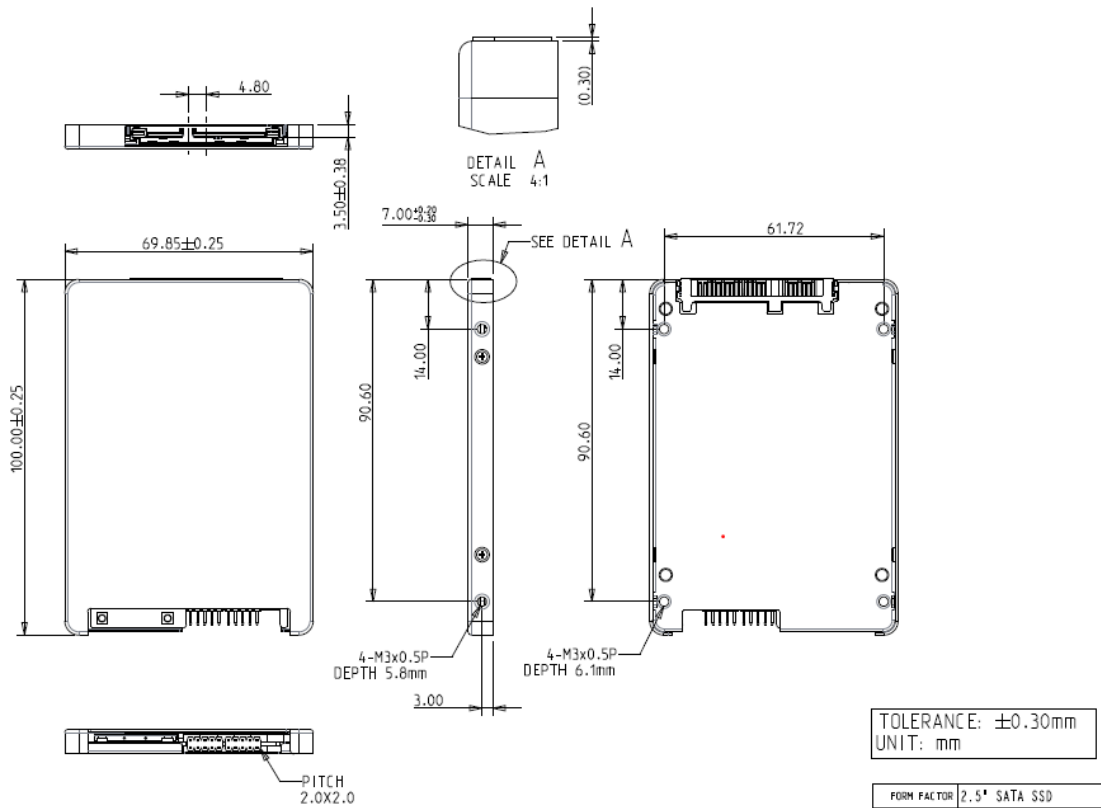

2. WiFi Antenna

Standard	IEEE 802.11 a/b/g/n and 802.11 ac
Frequency	2.4 to 2.49 GHz, 4.9 to 5.8GHz
Peak gain	3.5 dBi @2.44 GHz, 5.8 dBi @5.5 GHz
CSWR	<2.1
Feed impedance	50 ohms
Power handling	30 dBm
Interface	RPSMA
Antenna dimensions	Φ 13.0mmx198.0mm
Weight	27.8g
Temperature range	-30°C to 75°C
Cover material (color)	Plastic (black)
Humidity range	5% to 95%

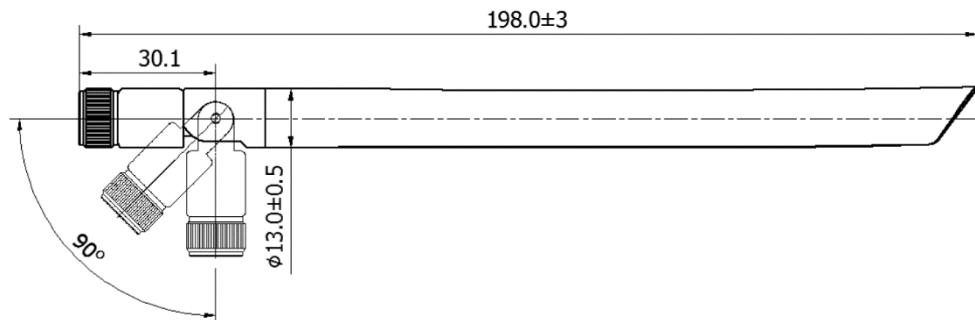

3. Ethernet Daughter Board

(1) Horizontal type

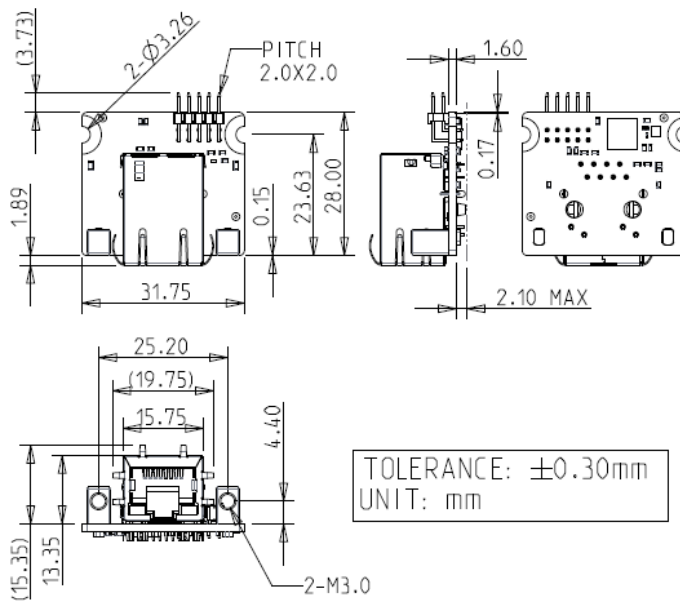

(2) Vertical type

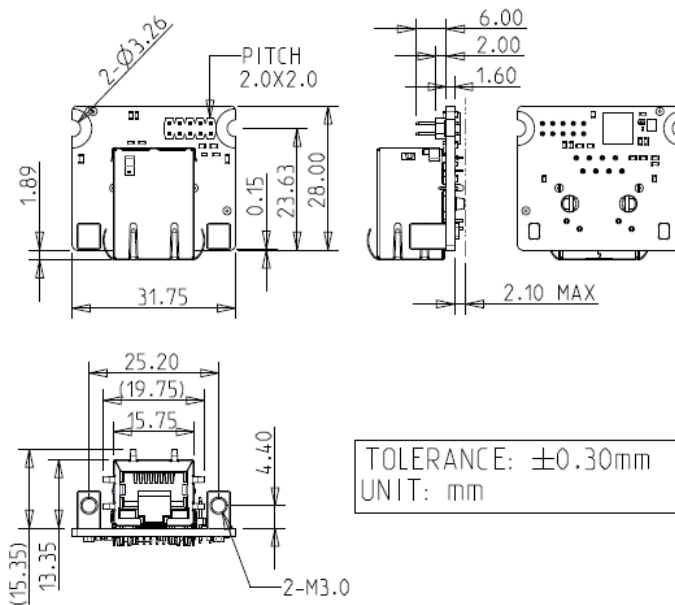

4. Cable Connection to Ethernet Daughter Board

