



I-9093

3-axis High-speed Encoder Module with
Compare Trigger Output

Features

- 3-axis, 32-bit Encoder Counter
- Maximum Counting Rate: 6 MHz
- Encoder Input: A, B, C Differential
- Encoder Mode: Quadrant, CW/CCW, PULSE/DIR
- Compare Trigger Output
- Selectable Reset/Latch Signal Inputs
- ± 4 kV ESD Protection
- 3000 VDC Intra-module Isolation



Introduction

I-9093 includes 3-axis encoder with compare trigger output function. It can generate a periodic trigger signal when the motor reaches a specified position. The specified position is called a breakpoint and is similar to a switch that is triggered after the motor passes a certain position. To use the compare trigger output function, you have to set an initial point (P) and a trigger period of the following points (D).

The trigger signal is an I/O line that can be used to fire another device. For example, when a motor reaches a certain position, the trigger signal can be used to fire the shutter of a camera to capture an image for the defect detection.

All operations of position compare and trigger pulse output are automatically done by the hardware circuit. There is no software calculation effort when the system is operating. I-9093 makes the system design simpler, and significantly increases the system performance.

I/O Specifications

System Specifications

LED Display	
Status	1 x Power and Communication 12 x I/O Signals
Isolation	
Intra-module Isolation, Field-to-Logic	3000 VDC
EMS Protection	
ESD (IEC 61000-4-2)	± 4 kV Contact for Each Terminal ± 8 kV Air for Random Point
Power	
Consumption	2 W Max.
Mechanical	
Dimensions (W x L x H)	31 mm x 134 mm x 144 mm
Environment	
Operating Temperature	-25 ~ +75 °C
Storage Temperature	-40 ~ +85 °C
Humidity	10 ~ 90 % RH, Non-condensing

Encoder Input	
No. of Axis	3
Response Speed	Quadrant: 2 MHz Max. CW/CCW: 6 MHz Pulse/Dir: 6 MHz
Resolution	32-bit
Programmable Digital Filter	1 ~ 250 μ s
Photo-isolation	2500 VDC
Mode	Quadrant , CW/CCW , Pulse/Dir
ON Voltage Level	+3.5 VDC ~ +5 VDC Or 10 VDC ~ 24 VDC (Jumper Select)
OFF Voltage Level	+0.8 VDC Max.
Compare Trigger Output	
Channels	3
Load Voltage	5 ~ 48 V
Max. Load Current	100 mA
Trigger Pulse Width	Yes
External Latch Input	
Channels	± 0.5 μ V/°C
ON Voltage Level	+3.5 VDC ~ +5 VDC Or 10 VDC ~ 24 VDC (Jumper Select)
OFF Voltage Level	+0.8 VDC Max.

Internal I/O Structure

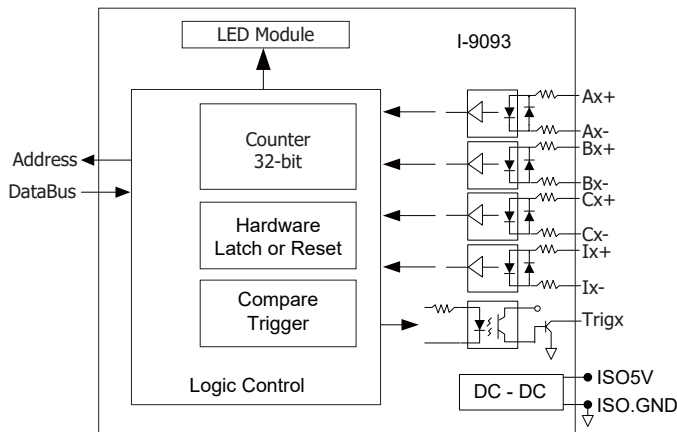

Pin Assignments

Pin Assignment	Terminal No.	Pin Assignment
A0+	01	17 A0-
B0+	02	18 B0-
C0+	03	19 C0-
I0+	04	20 I0-
Trig0	05	21 ISO.GND
A1+	06	22 A1-
B1+	07	23 B1-
C1+	08	24 C1-
I1+	09	25 I1-
Trig1	10	26 ISO.GND
A2+	11	27 A2-
B2+	12	28 B2-
C2+	13	29 C2-
I2+	14	30 I2-
Trig2	15	31 ISO.GND
ISO5V	16	32 ISO.GND

Wire Connections

Input Type	ON State LED ON Readback as 1	ON State LED OFF Readback as 0
Relay Contact	Relay ON 	Relay OFF
	Voltage > 4 V 	Voltage < 0.8 V
NPN Output	Open Collector ON 	Open Collector OFF
	Open Collector ON 	Open Collector OFF

Dimensions (Units: mm)

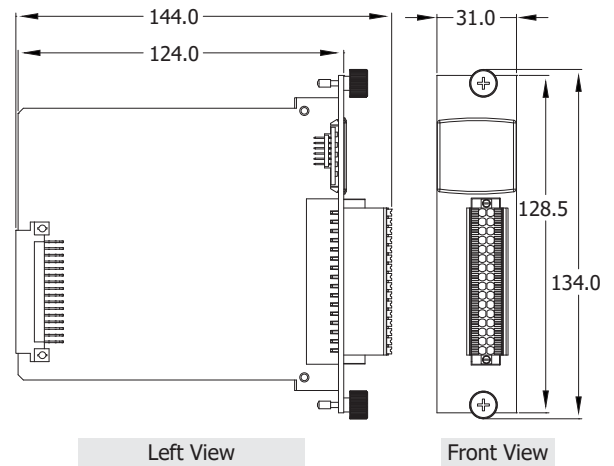

Output Type	ON State LED ON Readback as 1	ON State LED OFF Readback as 0
Drive Relay	Relay ON 	Relay OFF
	Resistance Load 	Resistance Load

Ordering Information

I-9093 CR 3-axis High-speed Encoder Module with Compare Trigger Output (RoHS)

ICP Electronics
Australia Pty Ltd

TEL: 02 9457 6011
sales@icp-australia.com.au
www.icp-australia.com.au

Proudly Australian-Owned Since 1999

