

Features

- Onboard Intel® Atom® x6000 series processors
- Onboard 8GB DDR4 memory + 1x DDR4 SO-DIMM, IB ECC compatible
- 1x I226IT PCI-E 2.5G LAN
- 2x USB 3.1, 4x USB 2.0, 2x SATA III, 2x UART (Tx/Rx only)
- 3x independent displays, DisplayPort /DVI-D / LVDS or eDP via carrier board (IP419)
- Supports wide-range operating temperature of -40°C ~ +85°C

Specifications

CPU	Intel® Atom® QC x6425E (1.8Ghz/3.0Ghz) Intel® Atom® DC x6211E (1.2Ghz/3.0Ghz)
PCH	Integrated in Intel® SoC
Memory	Onboard DDR4 8GB & 1x DDR4 SO-DIMM, Max. support 24GB, IB ECC compatible
BIOS	AMI
Watchdog Timer	256 levels
H/W Monitor	Yes
Storage Device Interface	N/A
Expansion Slots	5x PCI-E(x1) to carrier board
Graphics Controller	Intel® Gen11 integrated graphics
Video Output	2x DDI, LVDS or eDP on carrier board
Ethernet	1x Intel I226IT 2.5GbE RJ45 on carrier board
I/O Chipset	Fintek F81804U-I
Serial Port	2x COM ports (Tx/Rx only)
USB 2.0	4x USB 2.0 via carrier board
USB 3.X	2x USB 3.1 (5Gbps) via carrier board
Serial ATA	2x SATA III via carrier board
Audio	Built-in HD Audio controller
TPM	TPM (2.0)
Others	Digital I/O (4-in/4-out)
Dimensions (L X W)	95mm x 95mm (3.74" x 3.74")
Power Consumption	TBD
Operating Temperature	-40°C ~ +85°C (-40°F ~ +185°F) ; exclude SO-DIMM memory module
Storage Temperature	-40°C ~ 90°C (-40°F ~ +194°F)
Relative Humidity	90% (non-condensing @60°C)

Ordering Information

ET880-6425E	COM Express (Type-6) module w/ Intel® Atom® x6425E SoC on board, supports eDP
ET880-6425ELV	COM Express (Type-6) module w/ Intel® Atom® x6425E SoC on board, supports LVDS
ET880-6211E	COM Express (Type-6) module w/ Intel® Atom® x6211E SoC on board, supports eDP
ET880-6211ELV	COM Express (Type-6) module w/ Intel® Atom® x6211E SoC on board, supports LVDS
HSET880-A	Heatsink for ET880 with Atom® x6000 series SoC
HSET880-1	Heat spreader for ET880 with Atom® x6000 series SoC

Dimensions and Drawing

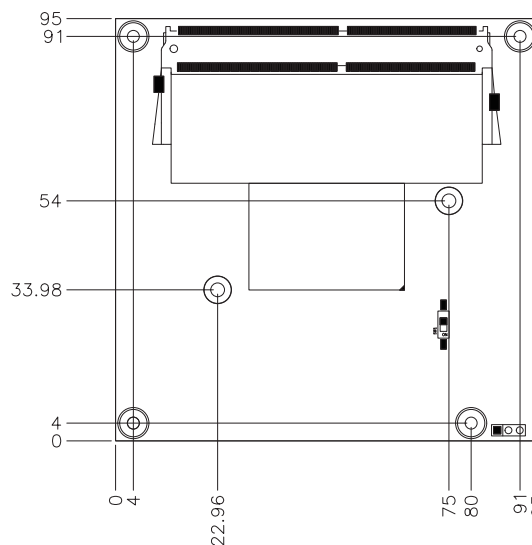

ICP Electronics
Australia Pty Ltd

TEL: 02 9457 6011
sales@icp-australia.com.au
www.icp-australia.com.au



Proudly Australian-Owned Since 1999