

# 10.1" P-Cap Chassis Display - W10L100-PCH2

## Features

- 10.1" 1280 x 800 Resolution
- Projected Capacitive Multi-Touch (P-Cap)
- Front IP65 Water and Dust Proof
- VGA input and variety of optional connectors
- USB port for touch
- Stylish and elegant design

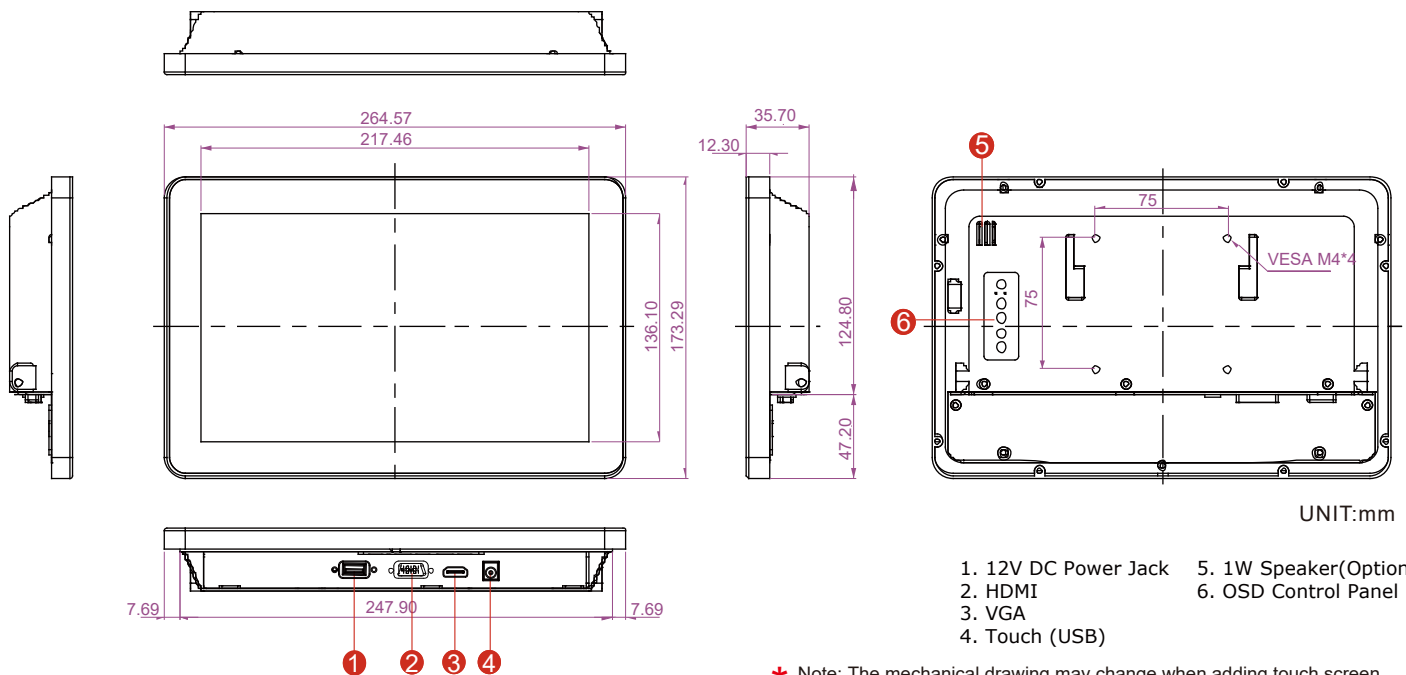

UNIT:mm

1. 12V DC Power Jack
2. HDMI
3. VGA
4. Touch (USB)
5. 1W Speaker(Optional)
6. OSD Control Panel

\* Note: The mechanical drawing may change when adding touch screen.  
Please contact our sales representative if you need further product information.

## Specifications

### Display

- Panel Size : 10.1"
- Active Display Area(mm) : 222.72(H)x125.28(V)
- Resolution : 1280x800
- Brightness(cd/m2) : 350(Typical)
- Contrast Ratio : 800:1 (Typical)
- Viewing Angles(CR>=10 L/R/U/D) : -85~85(H) ; -85~85(V)
- Display Colors : 16.7M (8 bits/color)
- Standard Input Signal : 1 x VGA (D-sub 15)

### Power Considerations

- Power Input : 12V DC, with external AC Adapter (100V~240V)
- Power Consumption : 10W typical , Normal operation

### Environment Considerations :

- Operating Temperature : -10 °C to 55 °C
- Operating Humidity : 10% to 95% (non-condensing)
- IP Rating : Front IP65

### Output

- Touch Screen : Projected Capacitive  
Optional anti-glare coating
- Touch Interface : USB
- Speakers (Optional) : Speaker x 1
- OSD : 5 Keys: - , + , Power , Esc , Enter

### Accessories

- Accessories : Power AC-DC Adapter(100V~240V)  
: VGA cable (1.8m)  
: HDMI cable (2m)  
: USB cable (1.8m)

### Optional

- Input Signal : 1 x HDMI (Type-A)\*