



DL-100S-E



DL-100S-E-W



DL-101S-E



DL-101S-E-W

Features

- Measurement Range: -20 to +60°C and 0 to 100% RH
- LCD Display Shows Temperature, Relative Humidity, Date and Time
- Able to store up to 600,000 records with date and time stamps
- Free Software Utility, iOS APP and Android App Included
- Supports the Modbus TCP and MQTT Protocols
- Includes redundant power inputs: PoE (IEEE 802.3af, Class 1) and DC input (DL-101S-E and DL-101S-E-W Only)
- PhotoMOS Relay Output for Alarm Devices or IAQ Device Control (DL-101S-E and DL-101S-E-W Only)
- Supports Web Configuration and Firmware Update via Ethernet
- IP66 Protection Approval
- DIN-Rail or Wall Mounted



Introduction

The DL-100S-E / DL-101S-E series of Data Logger devices can be used to record temperature, humidity and dew point information, including the date and time stamps for each record, with up to 600,000 downloadable records to be stored. Real-time data can be accessed from the DL-100S-E / DL-101S-E Data Logger from anywhere and at any time using the free Windows software, the iOS App, or the Android App, as long as it is connected to the same local network as the Data Logger. The DL-100S-E / DL-101S-E Data Logger supports popular industrial protocols such as Modbus TCP, as well as the emerging machine-to-machine (M2M) / IoT (Internet of Things) connectivity protocol – MQTT. The DL-100S-E / DL-101S-E Data Logger can be connected using a range of communication interfaces including Ethernet and PoE, meaning that the device can be easily integrated into existing HMI or SCADA systems, ensuring easy maintenance in a distributed control system.

The IP66 version of DL-100S-E / DL-101S-E series is designed for industrial applications in harsh environments that provides IP66 grade protection approval. The rugged RJ-45 ensures tight, robust connections, and guarantees reliable operation, even for applications that are subject to high vibration and shock.

Multi-platform Remote Access Software

Real-time data from the DL-100 Data Logger can be accessed from anywhere and at any time using the DL300 Utility, the iOS or Android App, or via a regular web browser, as long as it is connected to the same local network as the Data Logger.



Simple and powerful utility

The DL300 Utility can be used to configure the modules, monitor real-time data, or group DL-100 modules so that the status of distribution groups can be viewed and managed. The utility also allows the log data to be downloaded and exported to a .CSV file that can then be imported into any industry-standard software or spread sheet for analysis.

Supports the MQTT Protocol for IoT Applications

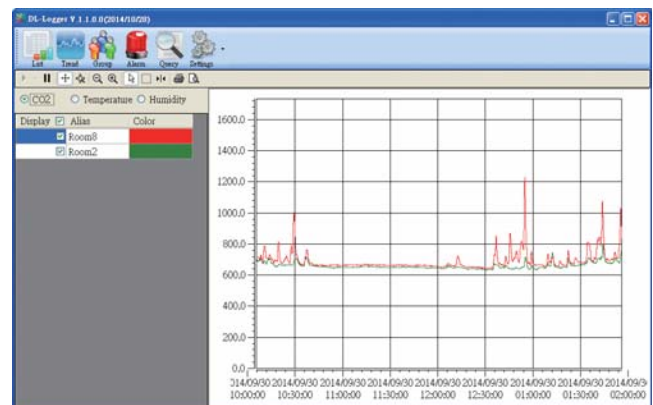
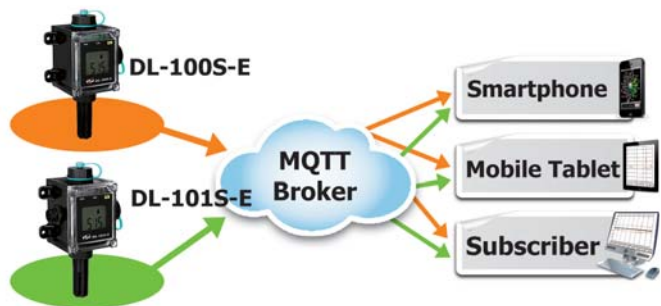

Specifications

Model	DL-100S-E	DL-100S-E-W	DL-101S-E	DL-101S-E-W
Temperature Sensor				
Measuring Range	-20 to +60°C (-31 to +176°F)			
Resolution	0.1°C			
Accuracy	Typical: ±0.4°C			
Humidity Sensor				
Measuring Range	0 ~ 100% RH			
Resolution	0.1% RH			
Accuracy	±3% RH @ 20 ~ 80% RH			
LCD and LED Display				
LCD Information Displayed	LCD Information Displayed Temperature (°C and °F), Relative Humidity, Date and Time			
PWR	System indicator (Green)			
Link	Link/Act indicator (Green)			
PoE	PoE indicator (Red)			
Communication				
Ethernet Port	10/100 Base-TX with Auto MDI/MDI-X			
PoE	Yes, (IEEE 802.3af, Class 1)			
Protocol	Modbus TCP, MQTT			
Security	Password and IP Filter			
Dual Watchdog	Yes, Module, Communication (Programmable)			
System				
Real-time Clock	Yes			
Data Logger	Yes, 600,000 Records			
PhotoMOS Relay Output	-		Form A×2, SPST 100 VDC @ 1 A	
Electrical				
Powered from Terminal Block	-		+12 to +48 VDC	
Powered from PoE	IEEE 802.3af, Class 1 (48 V)			
Power Consumption	PoE	0.7 W (Max.)		0.7 W (Max.)
	Non-PoE	-		0.6 W (Max.)
Mechanical				
Dimensions (W x L x H)	92 mm x 157 mm x 56 mm		100 mm x 157 mm x 56 mm	
Waterproof Level	IP66			
Installation	DIN-Rail; Wall mounted			
Environment				
Operating Temperature	-20 to +60°C			
Storage Temperature	-30 to +80°C			
Ambient Relative Humidity	5 to 95% RH, Non-condensing			

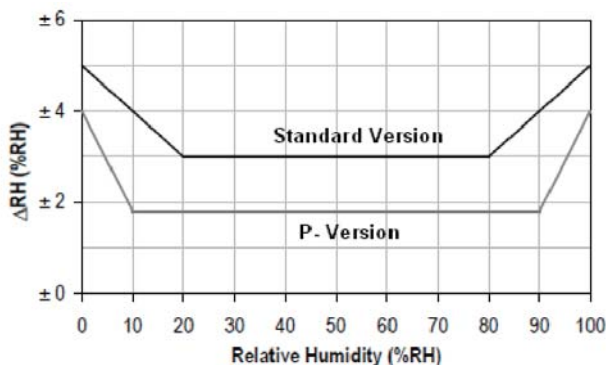

Maximum RH-tolerance at 25°C per sensor.

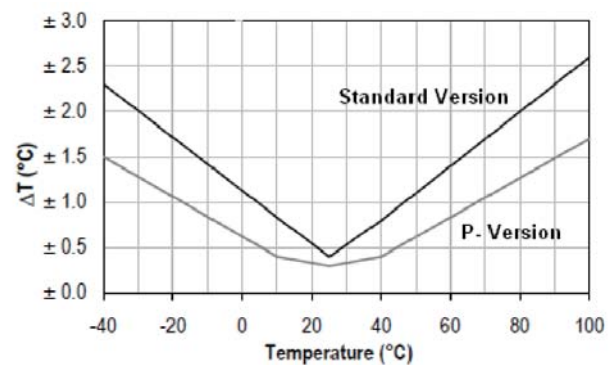

Maximum T-tolerance per sensor.

Applications

- Transportation of food or pharmaceuticals
- Food and beverage industry (HACCP)
- Blood stations, pharmacies
- Building and energy management
- Museums, archives, galleries
- Warehouses



Greenhouse Automation

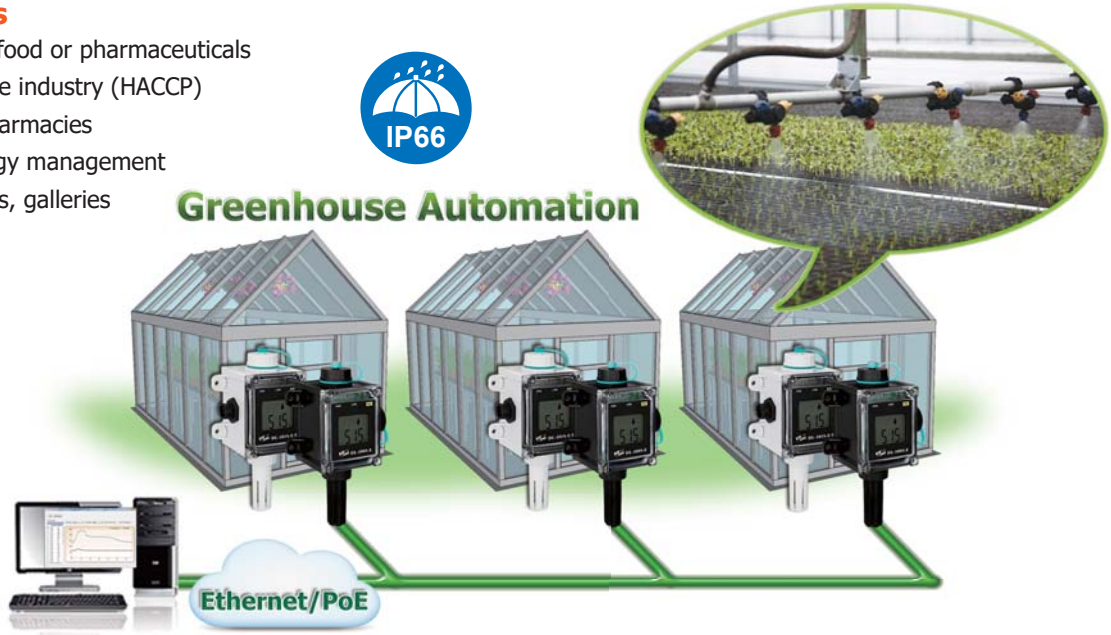

Installation

DIN-Rail



Wall mounted



Appearance

DL-100S-E



DL-101S-E

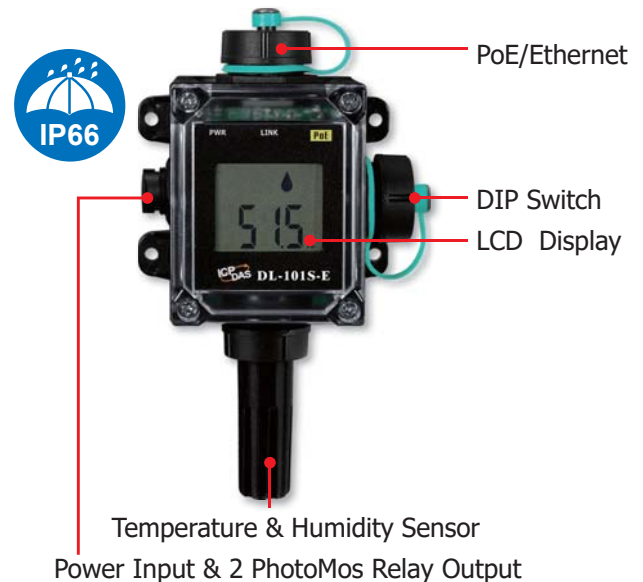

■ Dimensions (Units: mm)

DL-100S-E

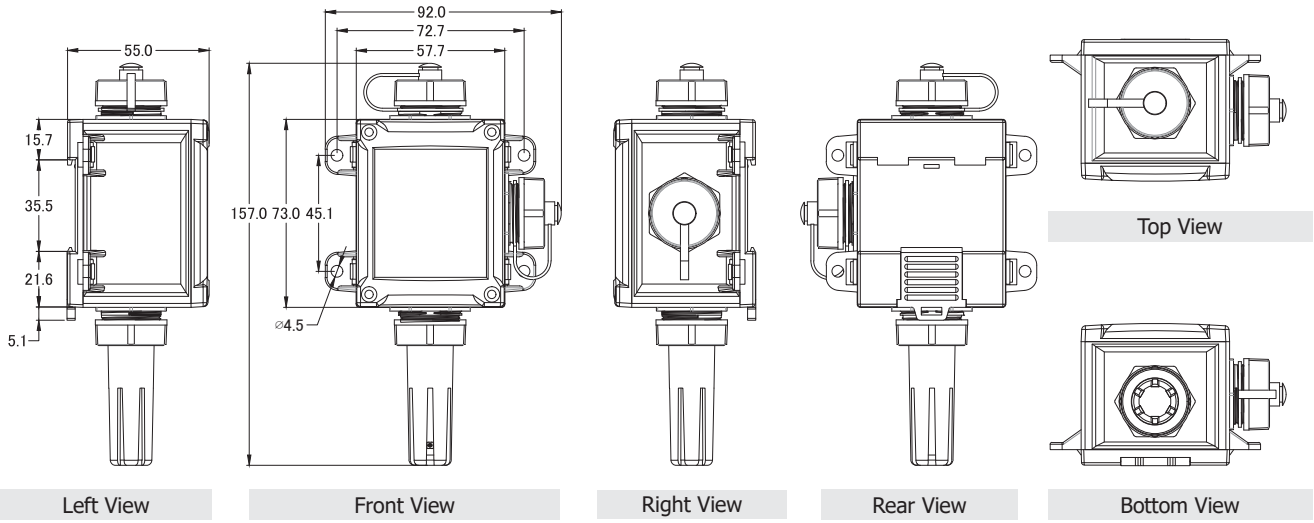



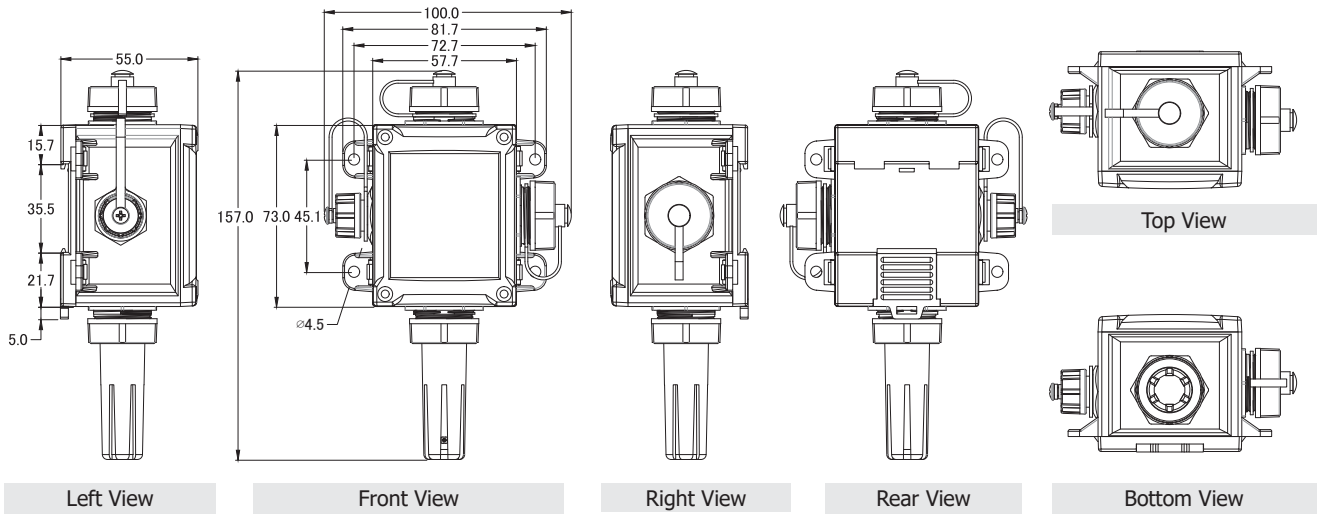

DL-101S-E



Ordering Information

DL-100S-E CR	Remote Temperature and Humidity Data Logger with LCD Display (Black Cover) (RoHS)
DL-101S-E CR	Remote Temperature and Humidity Data Logger with Safety Alarm (Black Cover) (RoHS)
DL-100S-E-W CR	DL-100S-E-W (White Cover) (RoHS)
DL-101S-E-W CR	DL-101S-E-W (White Cover) (RoHS)

Accessories

Model	NS-205-IP67	NS-205PSE-IP67	NS-208PSE-IP67	NS-208-IP67
				
PoE	–	802.3af x 4	802.3af x 8	–
Input Voltage Range	+10 VDC ~ +30 VDC (1 kV Isolated)	+46 VDC ~ +53 VDC		+12 VDC ~ +53 VDC
Installation	Wall Mounted	Wall Mounted	Wall Mounted	
Dimensions (W x L x H) (Units: mm)	85 x 76 x 137	85 x 76 x 137	190 x 155 x 104	

MDR-60-48	48 V/1.25 A, 60 W Power Supply with DIN-Rail Mounting
DIN-KA52F-48	48 V/0.52 A, 25 W Power Supply with DIN-Rail Mounting
DR-120-48	48 V/2.5 A, 120 W Power Supply with DIN-Rail Mounting

<p>IP67 RJ-45 Plug</p>  <p>4SASO-0001</p>	<p>Cap with Tether</p>  <p>4SASO-0004</p>	<p>IP67 Power Plug</p>  <p>4SIOIK0000013</p>
--	--	---