

# 20.1"

## Military Grade Console Display

### » Features & Benefits

- Model Name: R20L100-RKA2ML
- Certified with MIL-STD 810G
- Certified with MIL-STD 461E
- LED Backlight Panel
- High Image Quality Resolution up to 1600 x 1200 pixels
- Wide View Angle Display for  $\pm 89$  degrees
- Anti-Corrosion Housing / Fanless
- Standard AR Glass
- EMI ITO Mesh Filter Glass built-in (optional)
- 5 Wire Resistive Touch Screen with EMI Mesh Coating (optional)
- Flush Rack /Rack Mount Mechanical Design
- Convenient On-Screen Display Controls
- AC Power built-in / Optional 9~36V isolation DC in
- Built-in Light Sensor for auto brightness control
- Military Grade Power Connector (MIL-DTL-38999/1)
- Operating Temperature -0°C to 60°C
- Wide temperature solution by request
- Storage Temperature -10°C to 70°C

### » Technical Specifications

Display Specifications	
Model Name	R20L100-RKA2ML
Active Display Area	408.0(H) x 306.0(V) mm
Pixel Pitch	0.255(H) x 0.255 (V) mm
Brightness	300 cd/m <sup>2</sup> Optional up to 400 cd/m <sup>2</sup> (typical)
Viewing Angle	-89~89 (H); -89~89(V)
Contrast Ratio	800:1
Response Time	14 ms (typical)
Display Colors	16.7 Million (8 bits/colors)
Synchronization Range	Horizontal: 31.5~80.0kHz Vertical: 60~75 Hz
Input Interface	15 pin D-Sub, 5 x BNCs, DVI-D, RS232
Recommended Resolution	1600 x 1200 @60Hz
Power Source	AC 100~240V, Universal $\pm 10\%$ DC 9~36V $\pm 10\%$ (Optional)
Power Consumption	90W Typical, normal operation
Power Management	VESA DPMS Compliant
Plug & Play	VESA DDC 1/2B
Dimming Range	0~100 %
Light Sensor	Yes (default)
RS232 Remote Control	Optional
Glass	Yes (default) Standard Anti Reflective Glass
EMI ITO Glass	Optional, Transmittance 88%
Touch Screen	Optional, 5 Resistive Touch Screen
EMI Mesh Touch Screen	Optional, 5 Resistive Touch with EMI Mesh Filter
Optical bonding	MOQ required





### » Ordering Information

Part Number	Description
R20L100-RKA2ML/GS	Anti-Reflective Glass (Default)
R20L100-RKA2ML/ITO	ITO EMI shielding Glass *
R20L100-RKA2ML/ATR	ELO 5 wired Resistive Touch Sensor (RS232 Interface)
R20L100-RKA2ML/ATR-ITO	ELO 5 wired Resistive Touch with EMI Mesh Filter

\*To have MIL-STD-461E Compliance, it shall have EMI -ITO Glass or Touch with EMI Mesh Filter

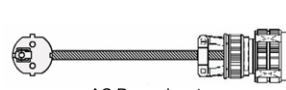
### » Accessories

Part Number
1. Military Grade 3 Pin Power Connector (conn. Type JY27466) 2 Meter
 AC Power input
 DC 9~36V Power input
2. Military Display Quick Installation Guide (Paper)
3. Touch Driver CD (Optional)
4. DVI Shielding Cable 1.8 Meter
5. VGA Shielding Cable 1.8 Meter
6. Touch RS232 Shielding Cable 1.8 Meter (Optional)
7. RS232 Remote Control Shielding Cable 1.8 Meter (Optional)

## » Military Grade EMC Compliance

EMC (MIL-STD 461E/F Compliance)					
EMC Test Spec	Type of Test	Frequency Range	Requirement	Default (V)	* Built-in EMI ITO Glass or Mesh Film Touch Sensor
CE101	Conducted Emissions	30Hz ~ 10kHz	30Hz ~ 1kHz :110 dB 1k-10k:110-90 dB	✓	✓
CE102	Conducted Emissions	30Hz ~ 10kHz	10kHz - 500KHz: 100-66dB .500KHz~10MHz:66dB	✓	✓
CS101	Conducted Susceptibility	30Hz - 150kHz	(Above 28 Volts) 30Hz-5KHz:136dbμV, 5KHz~150k Hz:136-106.5 dB		✓
CS106	Conducted Susceptibility	transients, power leads	(V <sub>peak</sub> = 400 V for 5.0 μsec, ±22%, V <sub>sag</sub> <= 120 V for <=20 μsec)		✓
CS109	Conducted Susceptibility	60Hz - 100kHz	(60-100kHz : 120-60dBμA)		✓
CS114	Conducted Susceptibility	10kHz ~200MHz	(10KHz~2MHz:49~89dbμA, 2MHz~30MHz:97dbμA, 30MHz~200MHz:97~89dbμA)		✓
CS115	Conducted Susceptibility	Impulse Excitation	(5A/ 30nS, at a 30 Hz rate for one minute)		✓
CS116	Conducted Susceptibility	10kHz - 100MHz	(Waveform: $e - (\pi f t) / Q \sin(2\pi f t)$ , $Q = \pi(N - 1)/\ln(IP/IN)$ , Peak current = 10A)		✓
RE101	Radiated Emissions	30Hz - 100kHz	(30-100k :180-110 dBpT)	✓	✓
RE102	Radiated Emissions	10kHz - 18GHz	(2MHz~18G Hz: 44-89 dB)	✓	✓
RS101	Radiated Susceptibility	30Hz - 100kHz	(30Hz-100kHz :180-116 dBpT)		✓
RS103	Radiated Susceptibility	2MHz - 40GHz	(2MHz-30MHz / 30MHz-1GHz / 1GHz-18GHz space :20V/m)		✓

\*To have MIL-STD-461E Compliance, it shall have EMI -ITO Glass or Touch with EMI Mesh Filter

\*If you require external test report, Winmate will charge NRE fee.

## » Mechanical Drawing

\* If you require external test report, Winmate will charge NRE fee.

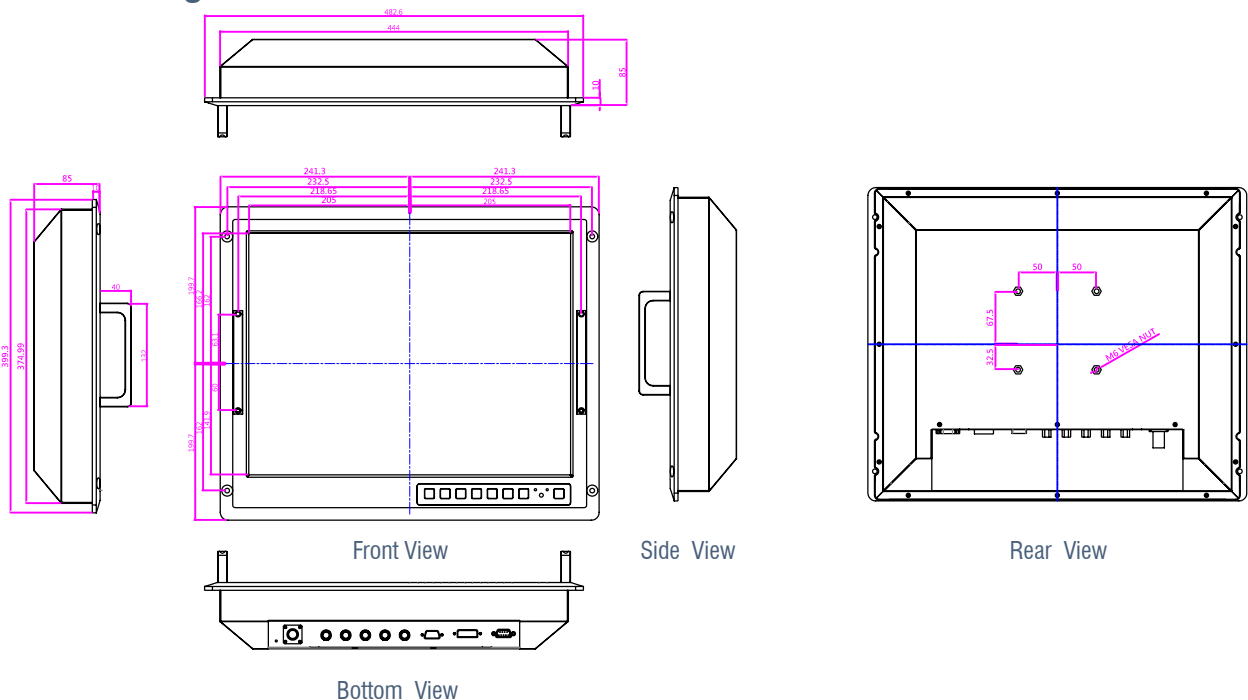

## » Military Grade Environmental Compliance

Environmentals (MIL-STD 810F/G Compliance)		
Humidity	30°C to 60°C, 95 ± 2% RH, Method 507.5	
Low Pressure	Operating	15,000 ft, Method 500.5 / Procedure II
	Storage	15,000 ft, Method 500.5 / Procedure I
Salt Fog	Method 509.5	
Vibration	5 ~ 500 Hz, 1.48 & 1.90 & 2.24 Grms Method 514.6 / Procedure I	
Transit Drop	Method 516.6 / Procedure IV	
Shock	Method 516.6 / Procedure I	
Rain / Water Resistance	Method 506.4 / IPX5 test and IP6X test	

## » Front On-Screen Display Control Functions

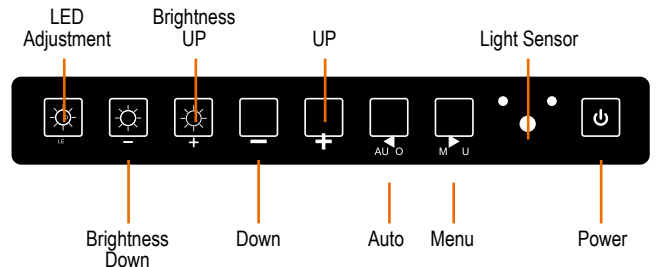

## » I/O Port Indications

