

15" E-Series HMI with Bay Trail Platform

- 15" 1024 x 768 Resolution
- P-cap Multi-touch screen
- Front IP65 Water and Dust Proof
- Dual Gigabit Ethernet
- Fanless cooling system and Ultra-low power consumption

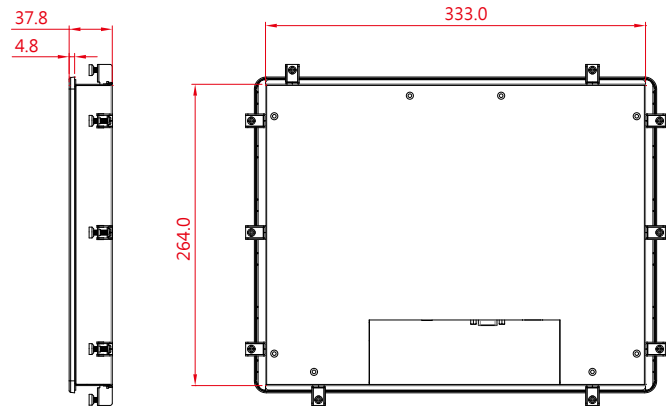
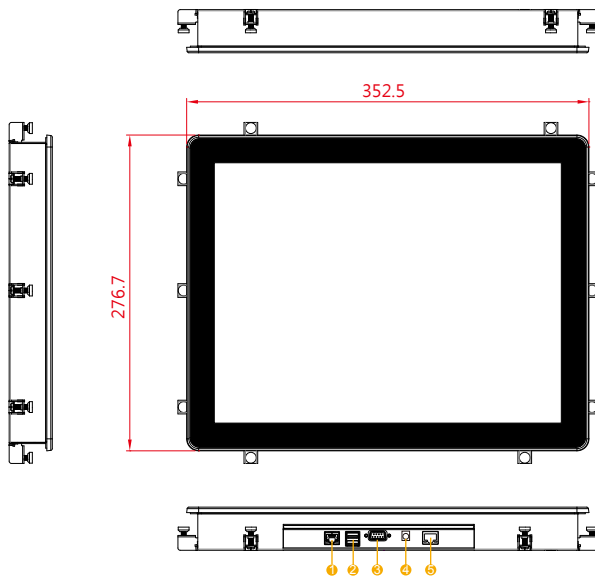

1. RJ-45 (LAN)
2. USB 2.0/USB 3.0
3. RS232/422/485
4. 12V DC in
5. RJ-45 (LAN or Optional PoE)

Specifications

System

- Processor : Intel® Celeron® Bay Trail-M N2930 1.83GHz
- System Chipset : Intel® ATOM SoC Integrated
- System Memory : 2GB DDR3L 1600 SODIMM (Optional 8G)
- Storage : 64GB mSATA SSD
- LAN : Dual Intel® I210-AT GbE LAN
- Security : Trusted platform module (TPM 1.2)

Input / Output :

- Serial Ports : 1 x RS-232/422/485
- USB Ports : 1 x USB 3.0, 1 x USB 2.0
- Ethernet : 1 x RJ 45-10/100/1000 Mbps (LAN)
1 x RJ 45(Optional PoE)

Software Support

- Watchdog SDK

Power Specifications :

- Power Input : 12V DC in Jack
- Power Consumption : 21W(typ.)

Display Spec :

- Size/Type : 15"
- Resolutions : 1024 x 768
- Brightness : 300 nits
- Contrast Ratio : 700:1 (typ.)
- Viewing Angle : -80~80(H); -80~80(V)
- Max Colors : 16.7M (8bit)
- Touch : Projected Capacitive Multi-Touch (P-CAP)
Optional anti-glare coating

Mechanical Specification :

- Cooling System : Fanless design
- Mounting : Mounting clips x 8
- Dimension (WxHxD) : 276.7 x 352.5 x 56.3 (mm)
- Front Bezel : Panel Mount design with Front IP65

Environment Considerations :

- Operating Temperature : -10 deg.C to 50 deg.C
- Operating Humidity : 10% to 90% (non-condensing)
- IP Rating : Front IP65

OS/BSP Driver Support :

- Operation System : Windows 10 IoT
Windows Embedded 8.1 Industry
Windows Embedded 8 Standard
Windows Embedded Standard 7