



- DL-301-IP65
- DL-302-IP65
- DL-303-IP65
- DL-304-IP65
- DL-305-IP65
- DL-306-IP65
- DL-307-IP65
- DL-308-IP65

Remote CO/CO2/HCHO/TVOC/NH3/H2S/Temperature/
Humidity/Dew Point Data Logger Module

Features

- Able to record CO, CO2, HCHO, TVOC, NH3, H2S, Temperature, Humidity, and Dew Point Measurements
- Non-dispersive Infrared (NDIR) CO2 Sensor
- Electrochemical Sensor
- 2.8" LCD Touch Screen
- Up to 450,000 records with date and time stamps
- Touch-screen and Web-based Configuration Interface
- Simple and Powerful Software Utility, iOS APP and Android App Included
- Able to Display Multilingual Messages on the Screen
- Supports the DCON, Modbus RTU/TCP, and MQTT Protocols
- Includes RS-485/Ethernet/PoE Communication Interfaces
- Relay Output for Audible/Visual Alarm or IAQ Device Control
- Includes redundant power inputs: PoE (IEEE 802.3af, Class 1) and DC input
- IP 65 Protection Approval



Introduction

The DL-300-IP65 series of Data Logger devices can be used to record CO, CO2, HCHO, TVOC, NH3, H2S, Temperature, Humidity and Dew Point information, including date and time stamps, and are able to store up to 450,000 downloadable records. Real-time data can be accessed from the DL-300-IP65 series Data Logger from anywhere and at any time using the free Windows software, the iOS App or the Android App, as long as they are connected to the same local network as the Data Logger. Support is provided for popular industrial protocols such as DCON, Modbus RTU, and Modbus TCP, as well as the emerging machine-to-machine (M2M)/IoT (Internet of Things) connectivity protocol-MQTT. The DL-300-IP65 series Data Logger can be connected via widely used communication interfaces including RS-485, Ethernet and PoE, meaning that the device can be easily integrated into existing HMI or SCADA systems, and is easy to be maintained in a distributed control system. The IP65 version of DL-300-IP65 series is designed for industrial applications in harsh environments that provides IP65 grade protection approval. The rugged RJ-45 ensures tight, robust connections, and guarantees reliable operation, even for applications that are subject to high vibration and shock.

Large 2.8" LCD Touch Screen, with clear Color Chart to indicate the CO/CO2 Level

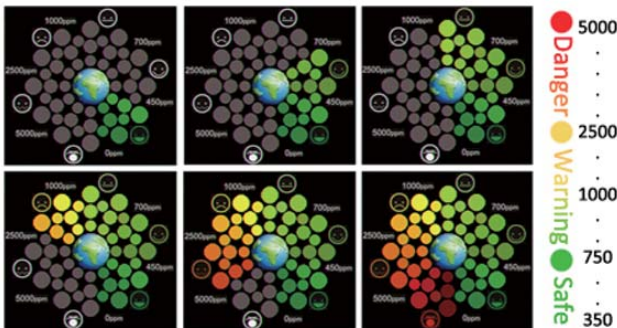

Simple and powerful utility

The DL300 Utility can be used to configure the modules, monitor real-time data, group DL-300 modules so that the status of distribution groups can be viewed and managed. The utility also allows the log data to be downloaded and exported to a .CSV file that can then be imported into any industry-standard software or spread sheet for analysis.

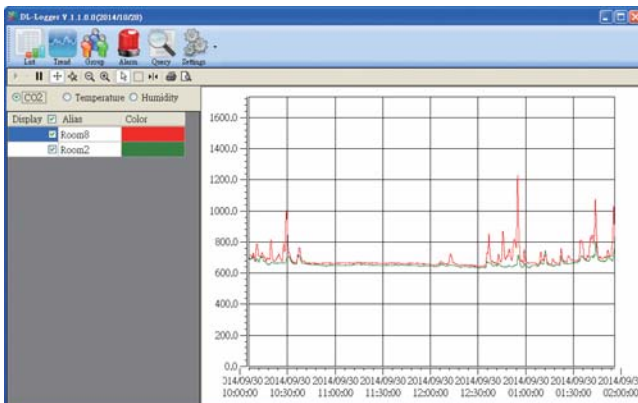

Supports the MQTT Protocol for IoT Applications

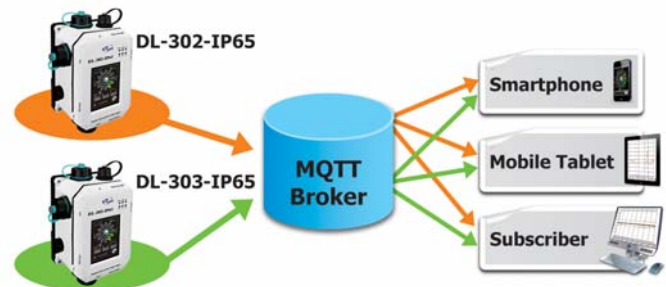

Multi-platform Remote Access Software

Real-time data from the DL-300 Data Logger can be accessed from anywhere and at any time using the DL300 Utility, the iOS or Android App, or via a regular web browser, as long as they are connected to the same local network as the Data Logger.



Display Messages in Multiple Languages

The display-message-on-screen function supports multiple language character sets based on UTF-8 encoding. Either pre-configured messages or dynamic messages can be remotely displayed using Modbus commands, or a dynamic message can be sent via the web-based interface.



Applications

Mushroom Farm

Mushroom growth yield requires long time to monitor the environment of CO₂ concentration, temperature and humidity values, and its growth environment is high humidity condition. The general equipment cannot work in such environment, but the DL-302-IP65 can be used to record CO₂, temperature, humidity and dew point information with date and time stamps in the operating temperature from -20°C to +50°C, and are able to store up to 450,000 downloadable records. The WISE-5231-3GWA features timer and schedule functions. It allows user to schedule specific date or time for control logic execution, or perform specific tasks such as time delay. With calendar user interface provided, schedule setting can be more efficient and flexible. This does not require programming, only some simple settings will be able to achieve the farm production control and quality control, production resume ... and so on.



Pig Farm

Ammonia and Hydrogen sulfide are two of the most harmful gases in animal farming environment. They will directly affect animals' growth and immunity. Pig farm requires long-term immediate monitoring the environment of NH₃ concentration, temperature and humidity values. The general equipment cannot work in such environment, but the DL-305-IP65 can be used to record NH₃, temperature, humidity and dew point information with date and time stamps in the operating temperature from -20°C to +50°C, and are able to store up to 450,000 downloadable records. The WISE-5231-3GWA features timer and schedule functions. It allows user to schedule specific date or time for control logic execution, or perform specific tasks such as time delay. With calendar user interface provided, schedule setting can be more efficient and flexible. This does not require programming, only some simple settings will be able to achieve the farm production control and quality control, production resume ... and so on.



System Specifications

Model	DL-301-IP65	DL-302-IP65	DL-303-IP65	DL-304-IP65	DL-305-IP65	DL-306-IP65	DL-307-IP65	DL-308-IP65	
System									
CO Alarm	Yes	-	Yes			-			
CO2 Alarm		Yes	Yes			-			
HCHO Alarm		-		Yes		-	Yes	-	
TVOC Alarm		-		Yes		-		Yes	
NH3 Alarm		-			Yes		-		
H2S Alarm		-				Yes		-	
RH/Temperature Alarm	Yes								
Real Time Clock	Yes								
Data Logger	Yes, up to 450,000 records								
Relay Output	PhotoMos Relay × 4, 100 VDC @ 1 A								
Communication									
RS-485 Port	Baud Rate = 1200 ~ 115200 bps								
Ethernet Port	10/100 Base-TX, 8-Pin RJ-45 x1(Auto-negotiating, Auto-MDI/MDIX, LED indicators)								
Security	IP filter (whitelist) and Password (web)								
Protocol	Modbus/RTU(RS-485), Modbus TCP(Ethernet) and MQTT(Ethernet)								
Dual Watchdog	Yes, Module (2.3 sec), Communication (Programmable)								
LED Indicators									
PWR	Green for normal operation								
Link	Green for the Ethernet-linked								
S1 ~ S4	Red for an alarm condition								
Main Machine Interface									
LCD	2.8 TFT (Resolution 240 x 320 x 16), Defective Pixels <= 3								
Backlight Life	20,000 hours								
Brightness	160 cd/m2								
Touch Panel	Yes								
Electrical									
Powered from Terminal Block	+12 to +48 VDC								
Powered from PoE	IEEE 802.3af, Class 1 (48 V)								
Power Consumption	PoE	2.9 W (Max.)	3.0 W (Max.)	3.1 W (Max.)	2.0 W (Max.)	2.9 W (Max.)	2.9 W (Max.)	2.1 W (Max.)	2.0 W (Max.)
	Non-PoE	2.7 W (Max.)	2.8 W (Max.)	2.8 W (Max.)	2.0 W (Max.)	3.0 W (Max.)	3.0 W (Max.)	2.1 W (Max.)	2.0 W (Max.)
Mechanical									
Installation	DIN-Rail or Wall Mounting								
Dimensions (L x W x H)	170 mm x 117 mm x 60 mm								
Environment									
Operating Temperature	-20 to +50°C								
Storage Temperature	-30 to +75°C								
Humidity	10 to 90% RH, Non-condensing								
Protection Class	IP65								

I/O Specifications

Model	DL-301-IP65	DL-302-IP65	DL-303-IP65	DL-304-IP65	DL-305-IP65	DL-306-IP65	DL-307-IP65	DL-308-IP65
CO Measurement								
Range	0 to 1000 ppm (Electrochemical)	-	0 to 1000 ppm (Electrochemical)			-		
Resolution	1 ppm	-	1 ppm			-		
Accuracy	±5% of measured value	-	±5% of measured value			-		
Response Time	30 sec	-	30 sec			-		
Warm-up Time	300 sec	-	300 sec			-		
CO2 Measurement								
Range	-	0 to 9999 ppm (NDIR)				-		
Resolution	-	1 ppm				-		
Accuracy	-	±30 ppm ±3% of measured value				-		
Response Time	-	20 sec				-		
Warm-up Time	-	60 sec				-		
HCHO Measurement								
Range	-	-	0 ppb to 2000 ppb (Electrochemical)			-	0 ppb to 2000 ppb (Electrochemical)	-
Resolution	-	-	1 ppb			-	1 ppb	-
Accuracy	-	-	0 ~ 300ppb : ±30ppb > 300ppb : ±10%			-	0 ~ 300ppb : ±30ppb > 300ppb : ±10%	-
Response Time	-	-	≤60 sec			-	≤60 sec	-
Warm-up Time	-	-	180 sec			-	180 sec	-
TVOC Measurement								
Range	-	-	0 ppb to 60000 ppb (MEMS Metal Oxide)			-	0 ppb to 60000 ppb (MEMS Metal Oxide)	
Resolution	-	-	1 ppb			-	1 ppb	
Accuracy	-	-	±15%			-	±15%	
Response Time	-	-	60 sec			-	60 sec	
Warm-up Time	-	-	180 sec			-	180 sec	
NH3 Measurement								
Range	-	-	-	0 to 100 ppm (Electrochemical)			-	
Resolution	-	-	-	1 ppm			-	
Accuracy	-	-	-	±5% of measured value			-	
Response Time	-	-	-	< 40 Sec			-	
Warm-up Time	-	-	-	60 Sec			-	
H2S Measurement								
Range	-	-	-	-	0 to 100 ppm (Electrochemical)			-
Resolution	-	-	-	-	1 ppm			-
Accuracy	-	-	-	-	±5% of measured value			-
Response Time	-	-	-	-	< 30 Sec			-
Warm-up Time	-	-	-	-	60 Sec			-
Temperature Measurement								
Range	-20 to +50°C							
Resolution	0.1°C							
Accuracy	±0.6°C							
Relative Humidity Measurement								
Range	0 to 100% RH, Non-condensing							
Resolution	0.1% RH, Non-condensing							
Accuracy	±5% RH, Non-condensing							
Dew Point								
Range	Calculated using temperature and relative humidity							
Resolution	0.1°C							

Appearance





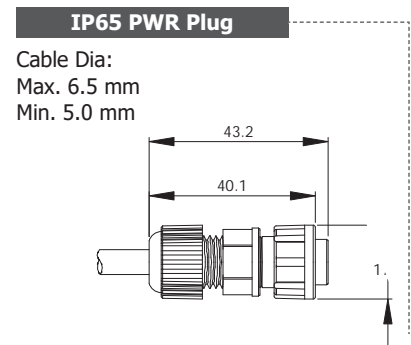
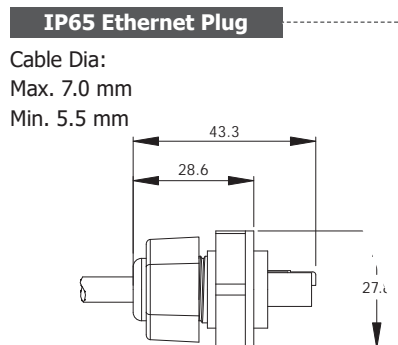
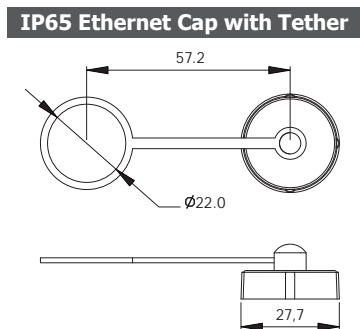
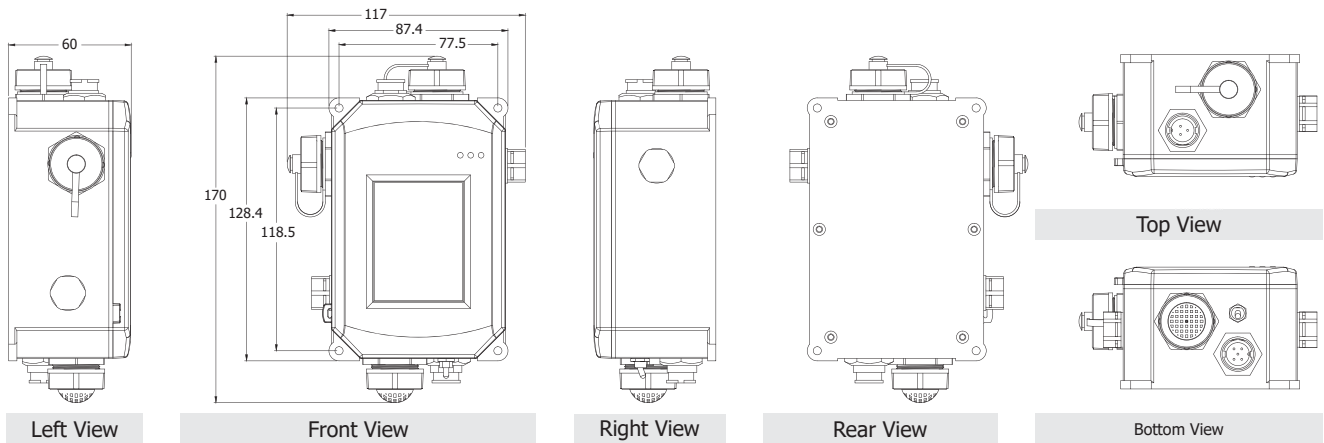

Dimensions (Units: mm)



Ordering Information

DL-301-IP65 CR	Remote CO/Temperature/Humidity/Dew Point Data Logger with Ethernet/RS-485 and PoE (RoHS)
DL-302-IP65 CR	Remote CO2/Temperature/Humidity/Dew Point Data Logger with Ethernet/RS-485 and PoE (RoHS)
DL-303-IP65 CR	Remote CO/CO2/Temperature/Humidity/Dew Point Data Logger with Ethernet/RS-485 and PoE (RoHS)
DL-304-IP65 CR	Remote HCHO/TVOC/Temperature/Humidity/Dew Point Data Logger with Ethernet/RS-485 and PoE (RoHS)
DL-305-IP65 CR	Remote NH3/Temperature/Humidity/Dew Point Data Logger with Ethernet/RS-485 and PoE (RoHS)
DL-306-IP65 CR	Remote H2S/Temperature/Humidity/Dew Point Data Logger with Ethernet/RS-485 and PoE (RoHS)
DL-307-IP65 CR	Remote HCHO/Temperature/Humidity/Dew Point Data Logger with Ethernet/RS-485 and PoE (RoHS)
DL-308-IP65 CR	Remote TVOC/Temperature/Humidity/Dew Point Data Logger with Ethernet/RS-485 and PoE (RoHS)

Accessories

Mode Name	NS-205-IP67	NS-205PSE-IP67	NS-208PSE-IP67	NS-208-IP67
Picture				
PoE	–	802.3af x 4	802.3af x 8	–
Input Voltage Range	+10 VDC ~ +30 VDC (1 kV Isolated)	+46 VDC ~ +53 VDC		+12 VDC ~ +53 VDC
Installation	Wall Mounting	Wall Mounting	Wall Mounting	
Dimensions (W x L x H)(Unit: mm)	85 x 76 x 137	85 x 76 x 137	190 x 155 x 104	

MDR-60-48	48 V/1.25 A, 60 W Power Supply with DIN-Rail Mounting
DIN-KA52F-48	48 V/0.52 A, 25 W Power Supply with DIN-Rail Mounting
DR-120-48	48 V/2.5 A, 120 W Power Supply with DIN-Rail Mounting

<p>IP67 RJ-45 Plug</p>  <p>4SASO-001</p>	<p>IP67 Power Plug</p>  <p>4SIO1K0000013</p>	<p>Cap with Tether</p>  <p>4SASO-0004</p>
---	---	--

ICP Electronics
Australia Pty Ltd

TEL: 02 9457 6011
sales@icp-australia.com.au
www.icp-australia.com.au

Proudly Australian-Owned Since 1999

