



Installation Cost Savings

Dramatically reduces cost of deployment – savings up to \$1,000 per PD



Simplifies Installation

Uses a single CAT-5/5e/6 cable for both data and electrical power



Centralized Power Backup

Continuous operation during power interruptions



Safe Power

Will not damage Non-PoE devices or legacy peripherals



Centralized Power Management

Devices can be remotely powered down during periods of low usage or for security purposes

GPOE-2P GPOE-4P

Power over Ethernet (PoE) technology allows a single Ethernet cable to carry both data and power to a device. It is used in various applications, such as transportation, surveillance and factory automation applications because of the installation convenience and high integration with current IT system. GPOE-4P with IEEE 802.3af (up to 30 watts per port) and GPOE-2P with IEEE 802.3at (up to 60 watts per port) can widen applications with flexible expansion interface.



GPOE-2P

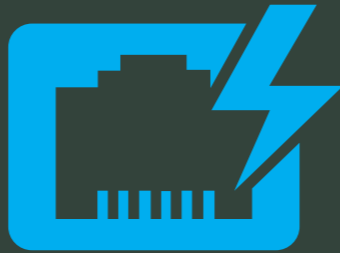

Centralized Power Backup

Continuous operation during power interruptions

Centralized Power Management

Devices can be remotely powered down during periods of low usage or for security purposes

12~24V wide range DC input

Support with dual DC-input connector



Support IEEE 802.3at for PoE (Power over Ethernet) with 30 watts per port

LED light for Identification

PCIe Switch IC

Both full-height and low profile brackets available
Easily built into any compact size system

PCI Express® x1 compliant

***Caution!** Choose one input only at a time.

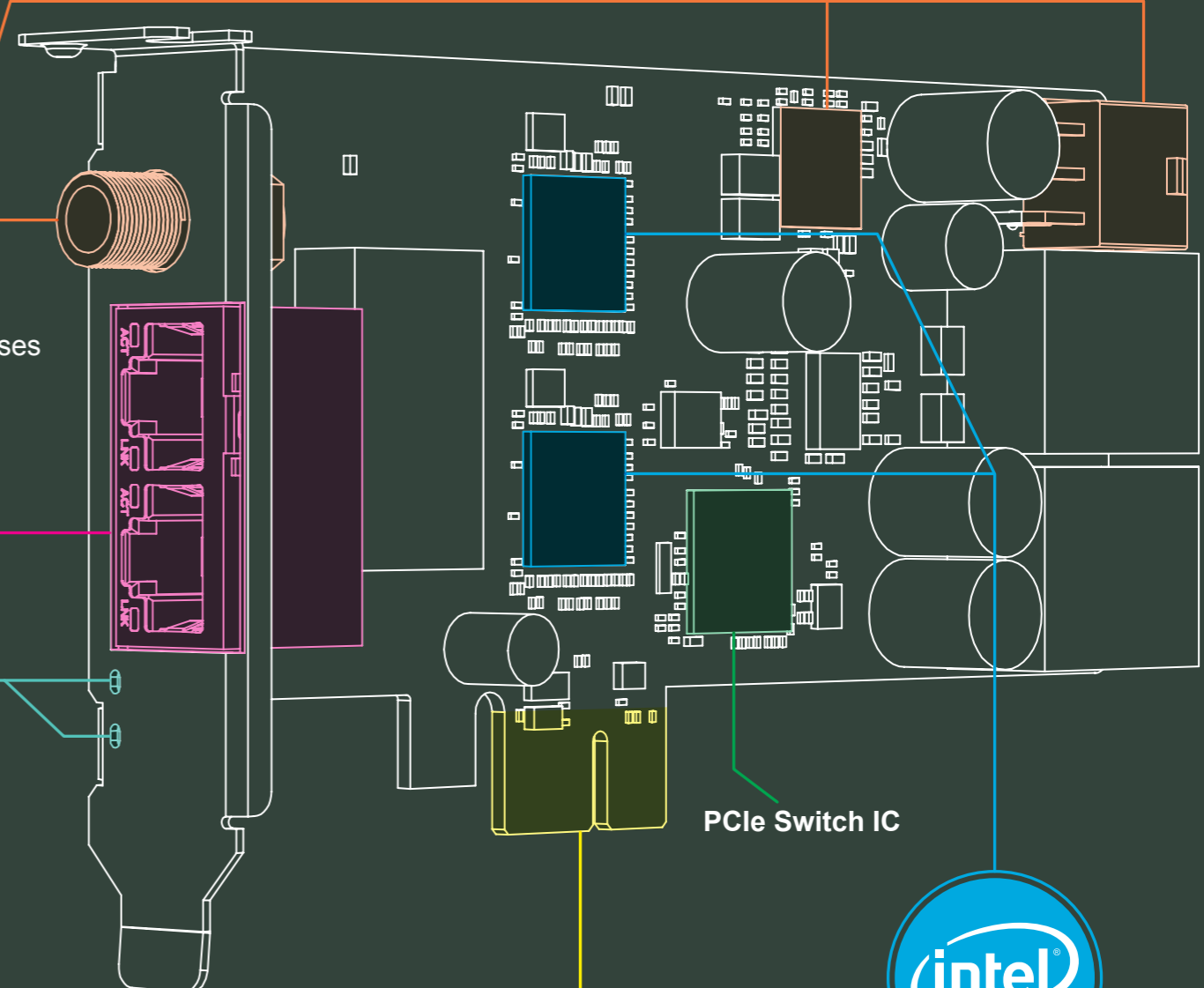

Intel® I211-AT Ethernet Controller
Link aggregation/jumbo frames (9 Kbyte)

ICP Electronics
Australia Pty Ltd

TEL: 02 9457 6011
sales@icp-australia.com.au
www.icp-australia.com.au



GPOE-4P

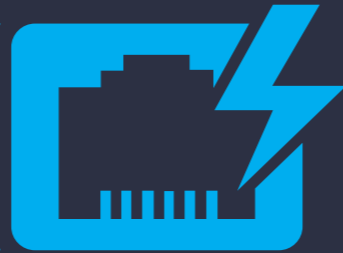

Centralized Power Backup
Continuous operation during power interruptions

Centralized Power Management
Devices can be remotely powered down during periods of low usage or for security purposes



Intel® I211-AT Ethernet Controller
Link aggregation/jumbo frames (9 Kbyte)



Support for total 90 watts under full load.

- Standard mode: IEEE 802.3af with 15.4 watts per port.
- Dual port mode: IEEE 802.3at with 30 watts per port.

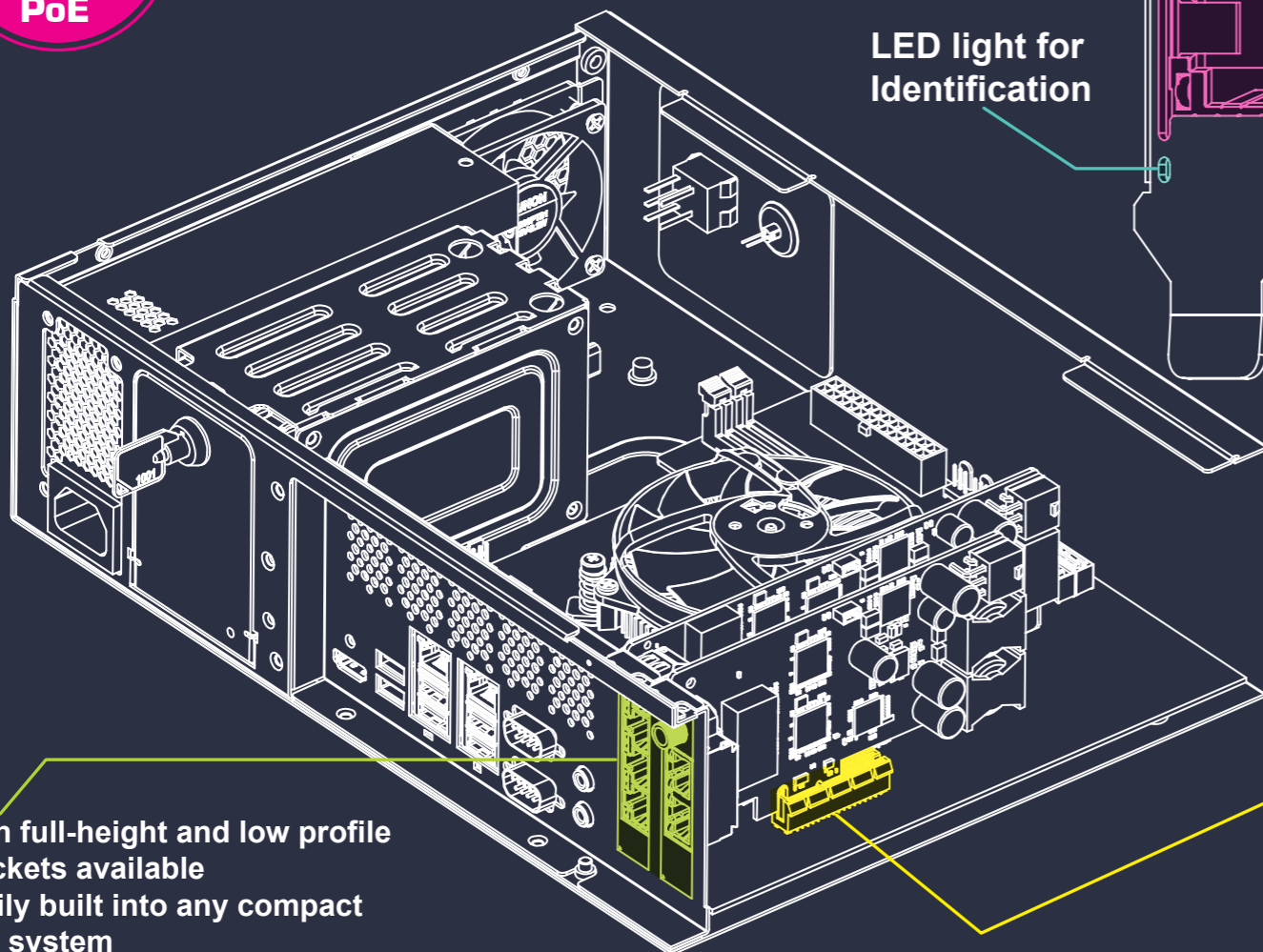

LED light for Identification

PCIe Switch IC

12~24V wide range DC input
Support with dual DC-input connector

***Caution!** Choose one input only at a time.

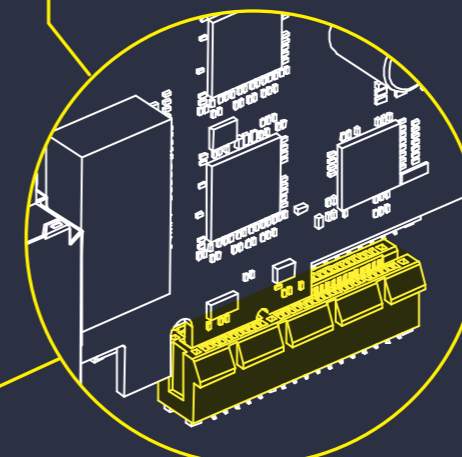

PCI Express® x1 compliant

Both full-height and low profile brackets available
Easily built into any compact size system

ICP Electronics
Australia Pty Ltd

TEL: 02 9457 6011
sales@icp-australia.com.au
www.icp-australia.com.au





Machine Vision

With PoE technology, users can easily connect various PoE PD supported IP camera to the control system through the standard CAT-5/CAT-6 cable (up to 100 meters) to transfer both electrical power and data at the same time. In this application, users can lower the difficulty of routing to avoid the risk of power adapter failure, and easily build the system to act as PSE, allowing the entire production process to be monitored and controlled from A to Z.

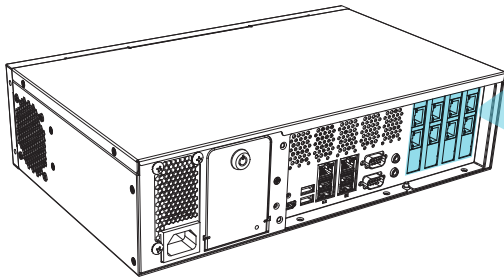

Installing
GPOE-2P & GPOE-4P

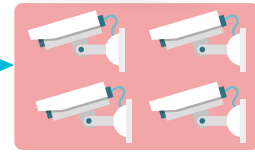

Access Control

Access control system can be easily developed by connecting PoE-capable devices like door controller, locking system and RFID reader. Combining power supply and data transmission in a single cable can save both cost and time on system installation. It is also easy to integrate IP-based system into the existing IP infrastructure.



Installing
GPOE-2P & GPOE-4P

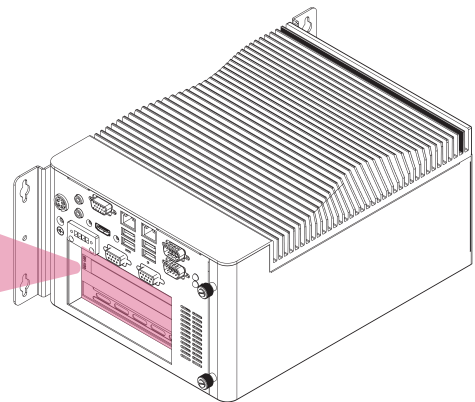

In-Vehicle System

The GPOE series can be easily added into in-vehicle control system and connect to various devices like surveillance camera, bus payment terminal or in-bus digital signage system. Both data and electrical power can run on standard CAT-5/CAT-6 cable to lower the difficulty of routing and avoid the risk of power adapter failure.



Installing
GPOE-2P & GPOE-4P

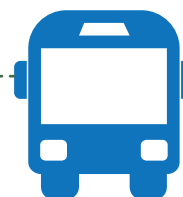

Cameras



Bus Payment
Terminal



GPOE-2P

PCI Express Power over Ethernet card, 2-port 1000 Base(T), 802.3at compliant, low profile, RoHS

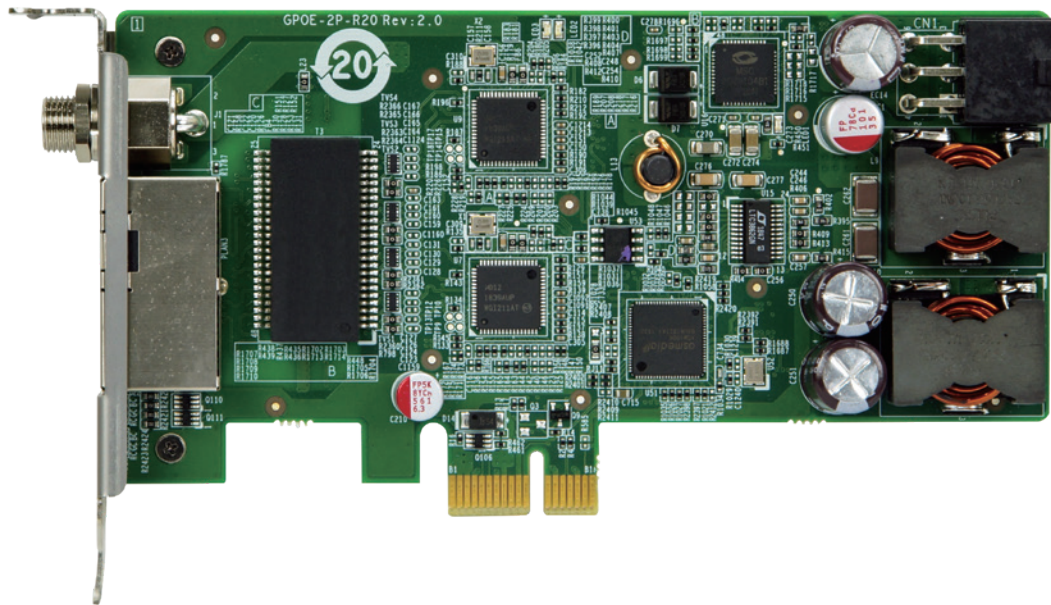

Specifications

- ◆ Interface
PCI Express® x1
- ◆ Ethernet
Intel® I211AT controller
9kB jumbo frame
IEEE 802.3az, IEEE1588
- ◆ Power Input
12~24V DC input
1 x Internal DC input (1x4 pin)
1 x External DC Jack (Φ2.1/Φ5.5)
****Caution! Choose one input only at a time**
- ◆ PoE Capability
IEEE 802.3at
30W / 52V DC per port (Support for total 60 watts under full load)
- ◆ Operating Temperature
0°C ~ 60°C
- ◆ Storage Temperature
-10°C ~ 70°C
- ◆ Operating Humidity
5% ~ 95%, non-condensing
- ◆ Dimensions
130 mm x 65 mm
- ◆ Weight
110g
- ◆ CE/FCC compliant

Features

- PCI Express® x1 compliant
- Support IEEE 802.3at for PoE (Power over Ethernet) with 30 watts per port
- Support link aggregation/jumbo frames (9 Kbyte)
- Supports 12V~24V DC input power

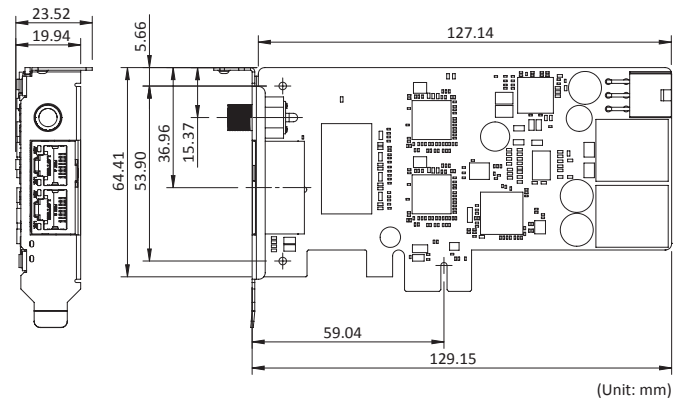

Packing List

- 1 x GPOE-2P card
- 1 x QIG (Quick Installation Guide)

Ordering Information

Part No.	Description
GPOE-2P-R20	PCI Express Power over Ethernet card, 2-port 1000 Base(T), 802.3at compliant, low profile, RoHS
32102-044900-100-RS	WIRE cable, power cable, PCIe power cable, 3, 100MM, 0AWG, (A) MOLEX 8981-04M P=5.08*2, (B) TKP: H6657R1-06-B-03 P=4.2, Polywell, RoHS
63040-010090-120-RS	Power adapter, FSP, FSP090-DIEBN2, 9NA0904712, Vin:90~264VAC, 90W, Plug=7.5mm, Cable=1500mm, Erp (no load 0.5W), Vout:19VDC, Φ2.1/Φ5.5/lock, CCL, RoHS
63040-010065-200-RS	Power adapter, FSP, FSP065-REBN2, 9NA0654709, Vin:90~264VAC, 65W, Dim:46.3x108.3x30mm, Plug=7.5mm, Cable=1500mm, Erp (no load 0.1W), Vout:19VDC, Φ2.1/Φ5.5/lock, CCL, RoHS



GPOE-4P

PCI Express Power over Ethernet card, 4-port 1000 Base(T), 802.3at/af compliant, low profile, RoHS

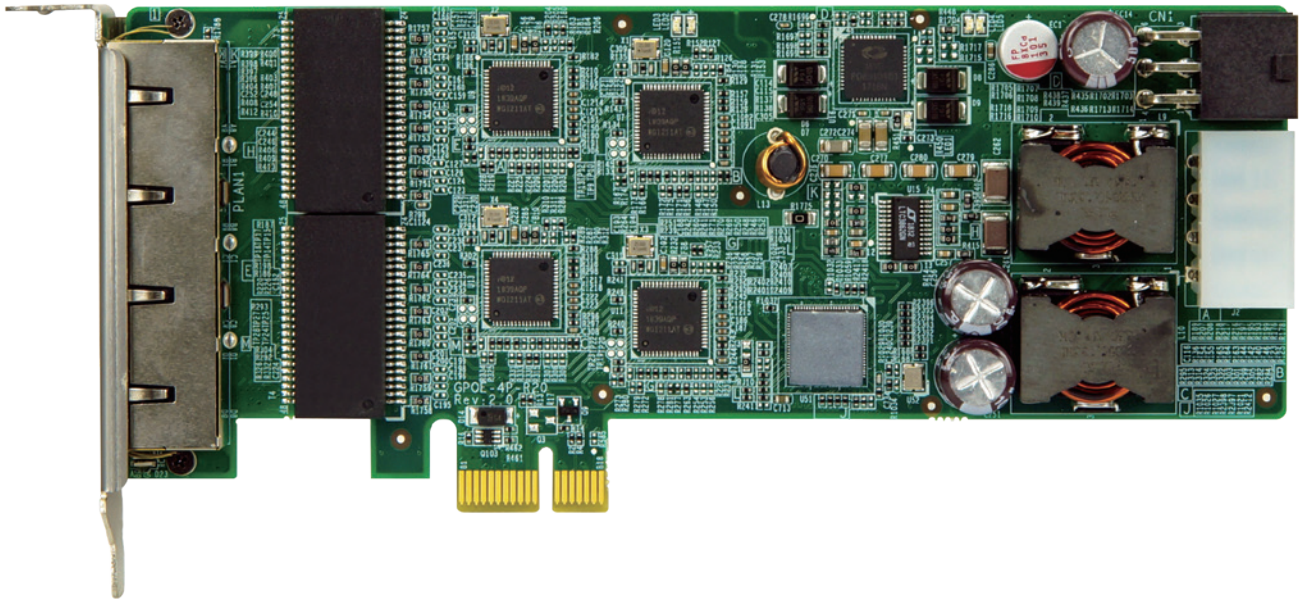

Specifications

- ◆ Interface
PCI Express® x1
- ◆ Ethernet
Intel® I211-AT controller
9kB jumbo frame
IEEE 802.3az, IEEE1588
- ◆ Power Input
12~24V DC input
1 x Internal DC input (1x4 pin)
1 x Internal DC input (2x3 pin)
****Caution! Choose one input only at a time**
- ◆ PoE Capability
Standard mode: IEEE 802.3af with 15.4W / 52V per port
Dual port mode: IEEE 802.3at with 30W / 52V per port
(Support for total 90 watts under full load)
- ◆ Operating Temperature
0°C ~ 60°C
- ◆ Storage Temperature
-10°C ~ 70°C
- ◆ Operating Humidity
5% ~ 95%, non-condensing
- ◆ Dimensions
160 mm x 65 mm
- ◆ Weight
110g
- ◆ CE/FCC compliant

Features

- PCI Express® x1 compliant
- Support for total 90 watts under full load
- Support link aggregation/jumbo frames (9 Kbyte)
- Supports 12V~24V DC input power

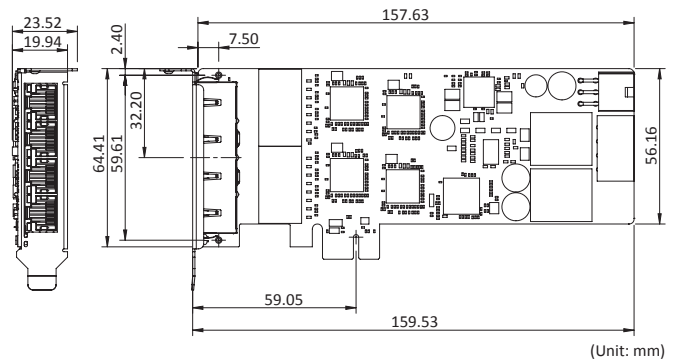

Packing List

- 1 x GPOE-4P card
- 1 x QIG (Quick Installation Guide)

Ordering Information

Part No.	Description
GPOE-4P-R20	PCI Express Power over Ethernet card, 4-port 1000 Base(T), 802.3at/af compliant, low profile, RoHS
32102-011500-100-RS	WIRE cable, power cable, 3, 150MM, 18AWG, MOLEX 8981-04P P=5.08 X2, MOLEX 8981-04M P=5.08, Wins Precision, RoHS
32102-044900-100-RS	WIRE cable, power cable, PCIe power cable, 3, 100MM, 0AWG, (A) MOLEX 8981-04M P=5.08*2, (B) TKP: H6657R1-06-B-03 P=4.2, Polywell, RoHS
32102-045800-100-RS	WIRE cable, power cable, 2, 300MM, 20AWG, (A) DC JACK 5.5*2.1+NUT+WASHER (Smcts:655-353), (B) TKP: H6657R1-06-B-03 P=4.2, Polywell, RoHS