

ICP Electronics
Australia Pty Ltd

TEL: 02 9457 6011
sales@icp-australia.com.au
www.icp-australia.com.au



Features

- 15" New Generation Stainless Steel Panel PC
- 4th Generation Intel Core i3-4010U/i5-4300U Onboard Processor
- True Flat Front Bezel Design and Grade 304 Stainless Steel Enclosure (Grade 316 for Option)
- IP66/IP69K Rated with M12 Connectors
- Support Resistive Touch, Projected Capacitive Touch, and Glass
- Touch on/off Button on the Side Edge for Hygienic Cleaning
- Support Ergonomic Versatile Mounting: Yoke Mounting / Space-saving VESA 75 x 75 mm Mounting

Specifications

System	
CPU	Onboard 4th Gen Intel Core i3/i5 Processor
System Chipset	SoC
Memory	Onboard 4GB DDR3L SDRAM , up to 8GB(option)

IO Port	
USB	1 x M12 8-pin for USB 2.0 with waterproof cover and chain
Serial / Parallel	1 x M12 8-pin COM1, RS-232/422/485, default RS-232, with waterproof cover and chain
LAN	1 x M12 8-pin for LAN with waterproof cover and chain
Others	1 x Touch on/off button on the side
Power Connector	1 x M12 3-pin for DC power with waterproof cover and chain 1 x Power switch on the side
Option	2 x optional blank M12 connector with waterproof cover and chain for selecting two from the following options: 2 x USB 2.0 1 x USB 3.0 1 x LAN (POE for option) 1 x COM 1 x CAN

Storage Space	
HDD	1 x 2.5" SATA3 HDD

Expansion	
Expansion Slot	1 x miniPCIe slot for WIFI/BT(optional), 4G/LTE(optional)
RFID module	RFID module design on the front side(optional)

Display	Standard	High Brightness Optional
Display Type	15" TFT-LCD	15" TFT-LCD
Max. Resolution	1024 x 768	1024 x 768
Max. Color	262K / 16.2M (optional)	262K / 16.2M (optional)
Luminance (cd/m ²)	420	1000
View Angle	160(H) / 160(V)	160(H) / 150(V)
Contrast	800:1	800:1
Backlight Lifetime	30,000 hrs	30,000 hrs

Touch Screen	
Type	Resistive Touch (For R model) Projected Capacitive Touch (For P model) Glass (For G model)
Interface	USB
Light Transmission(%)	Resistive Touch : 80% Projected Capacitive : 90%

Power	
Power Input	DC 9~36V
Power Consumption	ViTAM-915P:29W

Dimensions

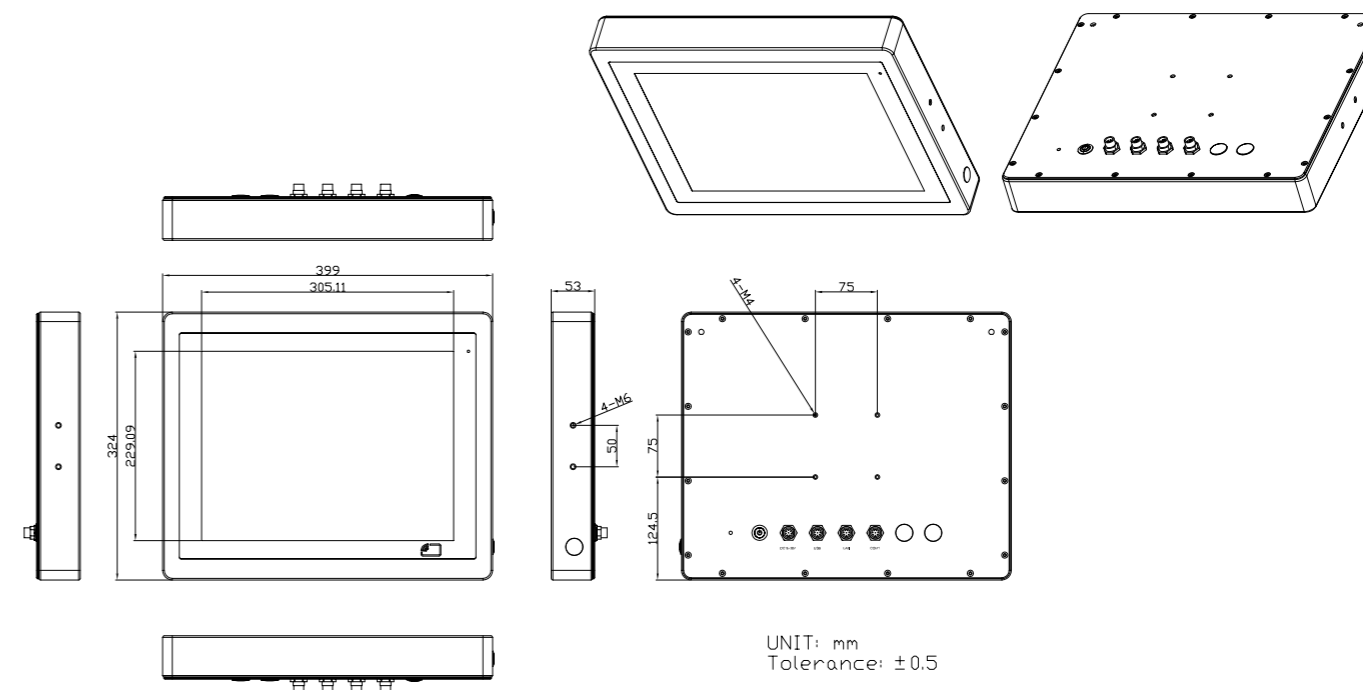

Mechanical	
Construction	304 Stainless steel chassis(default), 316 Stainless steel chassis(optional)
Mounting	VESA mount 75 x 75, Yoke mount for optional
IP Rating	Total IP66/IP69K
Dimensions	399 x 324 x 53 mm
Net Weight	7.1 kg

Environmental	
Operating Temperature	0~50°C
Storage Temperature	-30~70°C
Storage Humidity	10 to 90% @ 40°C, non- condensing
Certificate	CE/FCC Class A

Operating System Support	
Windows Embedded 7, Windows Embedded 8.1, Windows 10 IoT ENT LTSB	

Ordering Information	
ViTAM-915P	15" XGA IP66/IP69K stainless steel panel pc, Intel 4th Gen. Core i Processor, 4GB DDR3L RAM, 32G MLC SSD, projected capacitive touch, 9~36V DC power input with Adapter
ViTAM-915R	15" XGA IP66/IP69K stainless steel panel pc, Intel 4th Gen. Core i Processor, 4GB DDR3L RAM, 32G MLC SSD, 5 wire resistive touch window, 9~36V DC power input with Adapter
ViTAM-915G	15" XGA IP66/IP69K stainless steel panel pc, Intel 4th Gen. Core i Processor, 4GB DDR3L RAM, 32G MLC SSD, protection glass, 9~36V DC power input with Adapter
ViTAM-915PH	15" XGA IP66/IP69K stainless steel panel pc, Intel 4th Gen. Core i Processor, 4GB DDR3L RAM, 32G MLC SSD, projected capacitive touch, 9~36V DC power input with Adapter, 1,000 nits LCD
ViTAM-915RH	15" XGA IP66/IP69K stainless steel panel pc, Intel 4th Gen. Core i Processor, 4GB DDR3L RAM, 32G MLC SSD, 5 wire resistive touch window, 9~36V DC power input with Adapter, 1,000 nits LCD
ViTAM-915GH	15" XGA IP66/IP69K stainless steel panel pc, Intel 4th Gen. Core i Processor, 4GB DDR3L RAM, 32G MLC SSD, protection glass, 9~36V DC power input with Adapter, 1,000 nits LCD