



M2M Series Products



Remote maintenance Wi-Fi Device Terminal Unit



M2M-711D

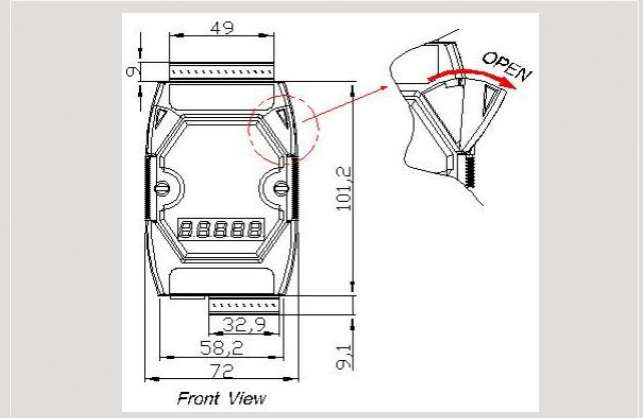

Dimensions

The M2M-711D module is specially designed for the remote maintenance and upgrading the serial to network application solution. Users can choose Ethernet or Wi-Fi to connect the VxServer software in PC.

In addition to M2M-710D original features, M2M-711D has the Ad Hoc mode of operation. This operation mode can be used to extend the distance of RS232/485 network without Wi-Fi AP and Ethernet Hub.

Features

- Provide pair connection (RS-232,RS-485) on network
- Web-based administration
- Support VxServer software
- Support Virtual COM technology
- Accommodatingly with M2M-420-A, M2M-720-A, M2M-710D
- Built-in MiniOS7 OS to keep off the computer virus
- Ethernet Protocol: TCP, UDP, IP, ICMP, ARP, RARP
- Supply static IP/DHCP (Ad Hoc mode don't support DHCP)
- Provide dynamic DNS function
- Supports IEEE 802.11 b/g for Wi-Fi mode
- Supports WEP-64, WEP-128, WPA-TKIP and WPA2-AES encryption for AP mode
- Supports WEP-64, WEP-128 encryption for Ad Hoc mode
- Supports 1~13 RF Channel
- Supports auto control RF channel in AP mode
- Auto control channel in AP mode
- Ad Hoc mode transmission range up to 100 m(Line of sight)
- Built-in web server
- Quick start
- 5-Digit 7 Segment LED Display
- EMI, RoHS compliance

Pin Assignments

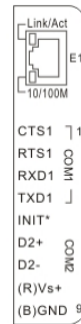

Pin	Name	Description
1	CTS1	Clear to Send
2	RTS1	Request to Send
3	RxD1	Receive Data
4	TxD1	Transmit Data
5	INIT	Init Pin
6	DATA+	Data+ of RS-485
7	DATA-	Data- of RS-485
8	Vs	Vs of Power Supply
9	GND	GND of Power Supply

Web-based administration

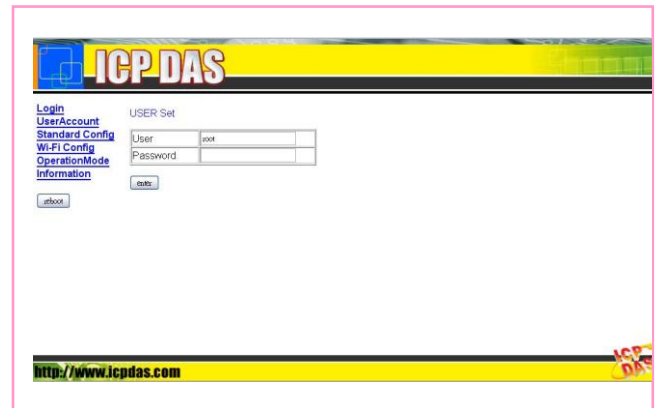

Hardware Specifications

System	
CPU	80186-80 MHz or compatible
SRAM	512K
Flash	Flash ROM: 512 KB ; Erase unit is one sector (64 KB) ; 100,000 erase/write cycles
EEPROM	16 KB, retention > 40 years. 1,000,000 erase/write cycles
Communication Interface	
COM ports	COM1:5-wire RS-232(RxD, TxD, RTS, CTS, GND); COM2: RS-485(DATA+, DATA-) Baud Rate : 1200/2400/4800/9600/19200/38400/57600/115200 bps Data Format: 7/8 data bits, None/Odd/Even parity bit, 1/2 stop bit
Ethernet	10/100 Base-TX Ethernet controller
Wireless Network Interface(IEEE 802.11b/g)	
RF channels	1~13; AP mode supports auto control channel.
Receive sensitivity	-87 dBm(IEEE 802.11b) / -72 dBm (IEEE 802.11g)
Data encryption	WPA-TKIP / WPA2-AES / WEP-64 /WEP-128 (It's not supported WPA-TKIP,WPA-AES encryption in Ad Hoc mode)
Transmit Power	12 dBm(IEEE 802.11b) / 14 dBm(IEEE 802.11g)
Antenna	2.4GHz - 5dBi Omni-Directional antenna
Transmission range	100M(LOS)
Power	
Protection	Power reverse polarity protection
Power supply	Unregulated +10 V _{DC} ~ +30 V _{DC}
Power Consumption	3.5W
LED Indicators	
5-Digit 7 Segment	Yes
System	Red
Wireless Network	Yellow
Mechanical	
Dimensions	72 mm x 33 mm x 123 mm (W x L x H) Detail
Installation	DIN-Rail or Wall Mounting
Environment	
Operating Temperature	-25 ~ +75 °C
Storage Temperature	-30 ~ +80 °C

Applications

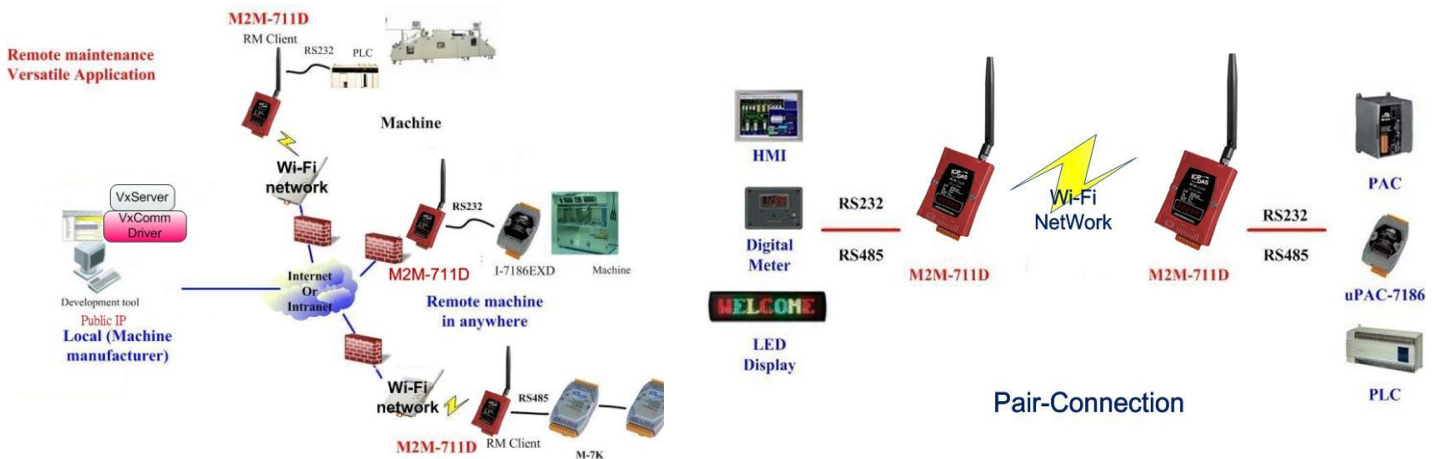

Ordering Information

M2M-711D	Remote maintenance Wi-Fi Device Terminal Unit
-----------------	---