



CAN Series Products



Intelligent RS-232 to CAN Converter



I-7530/I-7530T

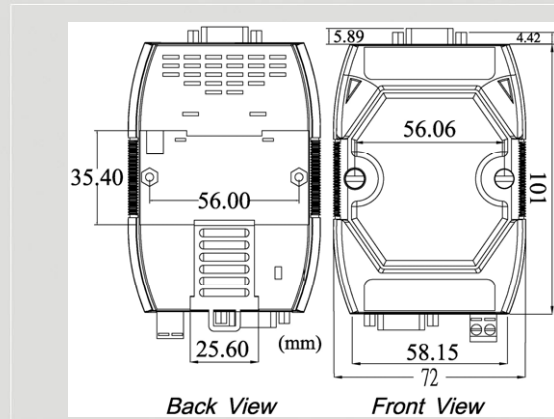

Dimensions

The PC can be the CAN host, monitor or HMI to access/control the CAN device through the CAN network by the I-7530/I-7530T converter. The programmable RS-232 device (For example: PACs of ICP DAS) can use the serial port to connect to the CAN network via the I-7530/I-7530T module. The I-7530/I-7530T is designed to unleash the power of CAN bus via RS-232 communication method. It accurately converts messages between CAN and RS-232 networks. This module let you communicate with CAN devices easily from any PC or devices with RS-232 interface.

Features

- Compatible with CAN specification 2.0A and B
- Fully compatible with ISO 11898-2 standard
- Support various baud rate from 10K bps to 1M bps
- Jumper for 120 Ω terminator resistor
- Software configurable CAN and RS-232 communication parameters
- 1000 frames in CAN received buffer, 900 frames in RS-232 received buffer
- Watchdog inside
- Support transparent communication mode
- Full-duplex communication mode of RS-232 devices is not supported

- Serial COM command error response selection
- Utility tool for transmitting / receiving CAN messages

CAN Monitor & Data log Tools

- Show CAN messages by hex or decimal format
- CAN messages with timestamp
- Easy-to-use data logger for the diagnosis of the CAN networks and recording of the received data
- Send the predefined CAN messages manually or cyclically

Utility Features

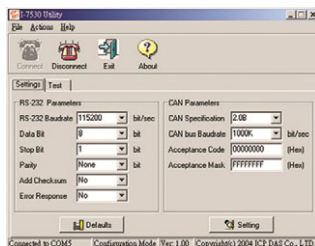

- CAN bus baud rate configuration
- CAN acceptance filter configuration
- CAN 2.0A or 2.0B specific selection
- Serial COM baud rate and data bit setting

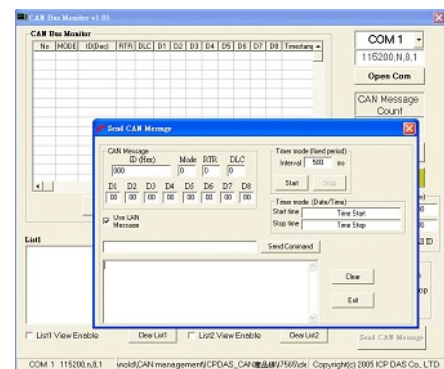

Wire Assignments

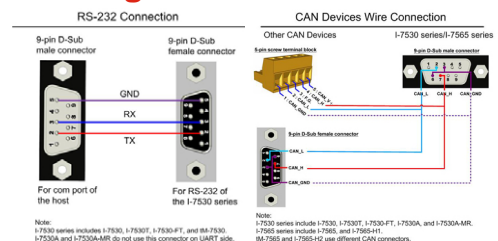



Hardware Specifications

CAN Interface	
Controller	Microprocessor inside with 20 MHz
Transceiver	NXP 82C250 or TJA1042 (only for I-7530T)
Channel number	1
Connector	9-pin male D-Sub (CAN_L, CAN_H, N/A for others)
Baud Rate (bps)	10 k, 20 k, 50 k, 125 k, 250 k, 500 k, 800 k, 1 Mbps
Transmission Distance (m)	Depend on baud rate (for example, max. 1000 m at 50 kbps)
Isolation	3000 V _{DC} for DC-to-DC, 2500 V _{rms} for photo-couple
Terminator Resistor	Selectable 120 Ω terminator resistor by jumper
Specification	ISO-11898-2, CAN 2.0A and CAN 2.0B
Receive Buffer	1000 data frames
UART Interface	
COM	RS-232
COM Connector	9-pin female D-Sub (TxD, RxD, GND, N/A for others)
Baud Rate (bps)	110, 150, 300, 600, 1200, 2400, 4800, 9600, 19200, 38400, 57600, 115200 bps
Data bit	5, 6, 7, 8
Stop bit	1, 2
Parity	None, Even, Odd
Receive Buffer	900 data frames
LED	
Round LED	ON LED: Power and Data Flow; ERR LED: Error
Power	
Protection	Power reverse polarity protection, Over-voltage brown-out protection
Power Consumption	1 W
Mechanism	
Installation	DIN-Rail
Dimensions	72mm x 118mm x 33mm (W x L x H)
Environment	
Operating Temp.	-25 ~ 75 °C
Storage Temp.	-30 ~ 80 °C
Humidity	10 ~ 90% RH, non-condensing

Applications

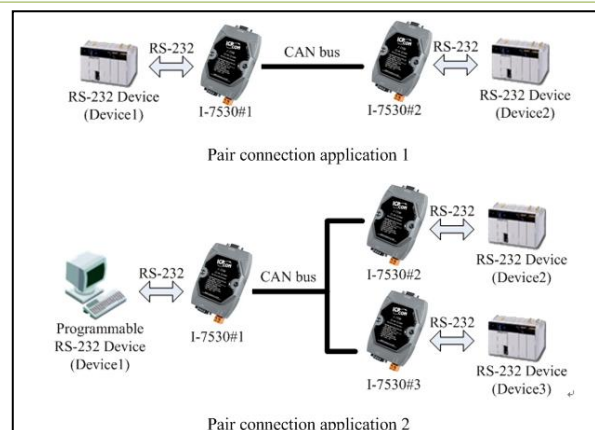
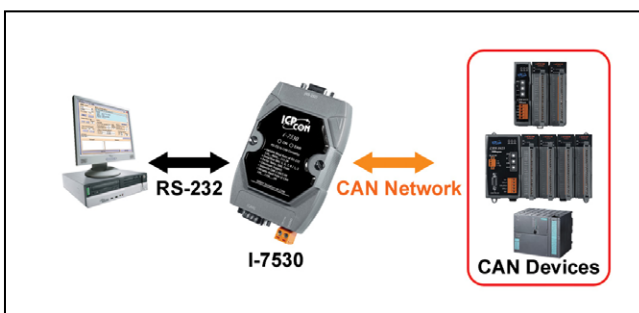

Ordering Information

I-7530-G	Intelligent RS-232 to CAN converter
I-7530-G CR	Intelligent RS-232 to CAN converter (RoHS)
I-7530T-G CR	Intelligent RS-232 to CAN converter (RoHS)