

**I-7052(D)**

**M-7052(D)**

8-channel Isolated Digital Input Module

**I-7053(D)\_FG**

**M-7053(D)**

16-channel Non-isolated Digital Input Module

**Features**

- I-7052(D)/M-7052(D)
  - Differential Digital Inputs
  - Sink- or Source-type Input
  - 4 kV ESD Protection
  - 5000 Vrms Isolation Voltage
- I-7053(D)\_FG/M-7053(D)\_FG
  - 16 Source-type Digital Inputs
  - Long Effective Distance
  - Dry Contact Input
  - Non-isolated for all Channels
- All Channels Can Be Used As 16-bit Counters
- Dual Watchdog
- Wide Operating Temperature Range: -25 to +75°C



**Introduction**

The I-7052 offers 6 fully independent channels and 2 common ground channels for digital input. The differential inputs feature channel-to-channel Photocouple isolation. In addition, you can choose either sink- or source-type input via wire connections. All channels are able to be used as 16-bit counters. The I-7052D has 8 LED indicators for DI channel status monitoring. 4 kV ESD protection and 5000 Vrms intra-module isolation are standard. The M-7052 has the same

hardware specifications as the I-7052, but provides additional support for the Modbus RTU protocol as well as the DCON protocol.

**System Specifications**

Model	I-7052	M-7052	I-7053_FG	M-7053
	I-7052D	M-7052D	I-7053D_FG	M-7053D
<b>Communication</b>				
Interface	RS-485			
Bias Resistor	No (Usually supplied by the RS-485 Master. Alternatively, add a tM-SG4 or SG-785.)			
Format	(N, 8, 1) (N, 8, 2) (E, 8, 1) (O, 8, 1)			
Baud Rate	1200 to 115200 bps			
Protocol	DCON	Modbus RTU, DCON	DCON	Modbus RTU, DCON
Dual Watchdog	Yes, Module (1.6 Seconds), Communication (Programmable)			
<b>LED Indicators/Display</b>				
System LED Indicator	Yes, 1 as Power/Communication Indicator			
I/O LED Indicators	Yes, 8 LEDs as Digital Input Indicators		Yes, 16 LEDs as Digital Input Indicators	
7-segment LED Display	-			
<b>Isolation</b>				
Intra-module Isolation, Field-to-Logic	5000 Vrms		-	
<b>EMS Protection</b>				
ESD (IEC 61000-4-2)	4 kV Contact for each Terminal		-	
	8 kV Air for Random Point		-	
EFT (IEC 61000-4-4)	±4 kV for Power Line		-	
Surge (IEC 61000-4-5)	-			
<b>Power</b>				
Reverse Polarity Protection	Yes			
Input Range	+10 ~ +30 Vdc			
Consumption	0.2 W	0.2 W	0.7 W	0.7 W
	0.6 W	0.6 W	0.9 W	0.9 W
<b>Mechanical</b>				
Dimensions (L x W x H)	123 mm x 72 mm x 35 mm			
Installation	DIN-Rail or Wall Mounting			
<b>Environment</b>				
Operating Temperature	-25 to +75°C			
Storage Temperature	-40 to +85°C			
Humidity	10 to 95% RH, Non-condensing			

The I-7053\_FG features a long effective distance measurement for dry contact digital input of up to 500 meters. The I-7053\_FG supports source-type input. All 16 channels are also able to be used as 16-bit counters, each of which are non-isolated. The I-7053D\_FG has 16 LED indicators for channel status monitoring. The M-7053 has the same hardware specifications as the I-7053\_FG, but provides additional support for the Modbus RTU protocol as well as the DCON protocol.

**Applications**

Building Automation, Factory Automation, Machine Automation, Remote Maintenance, Remote Diagnosis, Testing Equipment.

**I/O Specifications**

Model	I-7052	M-7052	I-7053_FG	M-7053
	I-7052D	M-7052D	I-7053D_FG	M-7053D
<b>Digital Input/Counter</b>				
Channels	8		16	
Type	Dry Contact		-	
	Wet Contact		Sink/Source	
Wet Contact	ON Voltage Level	+4 ~ 30 Vdc		-
	OFF Voltage Level	+1 Vdc Max.		-
Dry Contact	ON Voltage Level	-		Open
	OFF Voltage Level	-		Close to GND
	Effective Distance for Dry Contact	-		500 m Max.
Counters	Max. Count	65535 (16-bit)		
	Max. Input Frequency	100 Hz		
	Min. Pulse Width	5 ms		
Input Impedance	3 kΩ		-	
Channel-to-Channel Isolation	Yes, ±2 kV for differential only.		-	
Overvoltage Protection	±35 Vdc		-	

## Internal I/O Structure

I-7052(D)/M-7052(D)

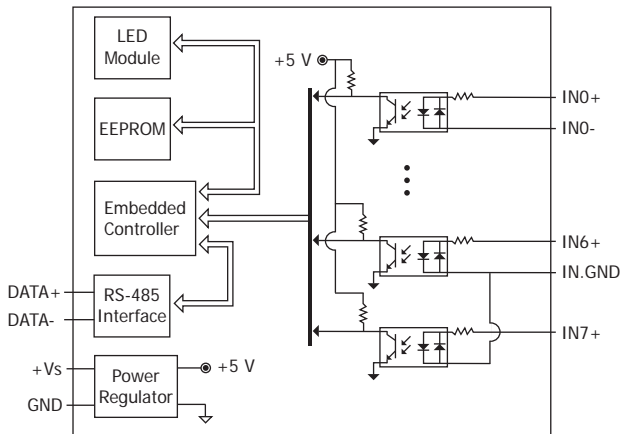

I-7053(D)\_FG/M-7053(D)

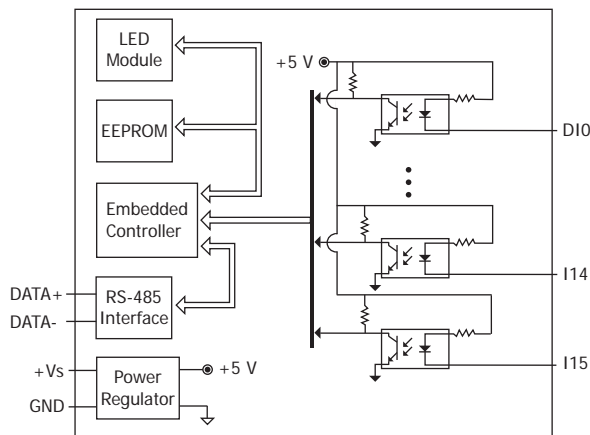

## Wire Connections

I-7052(D)/M-7052(D)

Digital Input/Counter	ON State Readback as 1 +4 ~ +30 VDC	OFF State Readback as 0 Open or +1 VDC Max.
Channel 0 to 5 Wet Contact (Sink)		
Channel 0 to 5 Wet Contact (Source)		
Channel 6 to 7 Wet Contact (Sink)		

I-7053(D)\_FG/M-7053(D)

Digital Input/Counter	ON State Readback as 1 OPEN or <4 VDC	OFF State Readback as 0 +3.5 ~ +30 VDC
Dry Contact		

## Pin Assignments

I-7052(D)/M-7052(D)

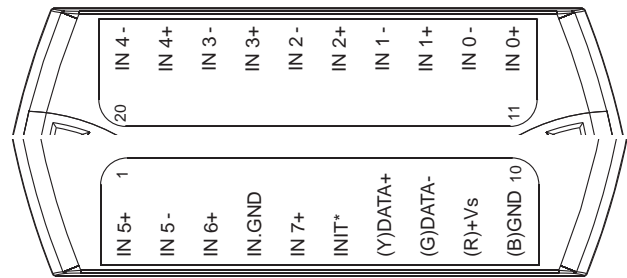

I-7053(D)\_FG/M-7053(D)

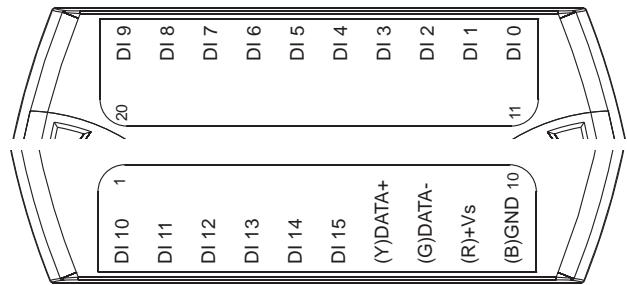

## Ordering Information

I-7052 CR	8-channel Isolated Digital Input Module using the DCON Protocols (Blue Cover) (RoHS)
I-7052D CR	I-7052 with LED Display (Blue Cover) (RoHS)
I-7052D-G CR	I-7052 with LED Display (Gray Cover) (RoHS)
M-7052-G CR	8-channel Isolated Digital Input Module using the DCON and Modbus Protocols (Gray Cover) (RoHS)
M-7052D-G CR	M-7052 with LED Display (Gray Cover) (RoHS)
I-7053_FG CR	16-channel Non-isolated Digital Input Module using the DCON Protocols (Blue Cover) (RoHS)
I-7053_FG-G CR	16-channel Non-isolated Digital Input Module using the DCON Protocols (Gray Cover) (RoHS)
I-7053D_FG CR	I-7053_FG with LED Display (Blue Cover) (RoHS)
I-7053D_FG-G CR	I-7053_FG with LED Display (Gray Cover) (RoHS)
M-7053-G CR	16-channel Non-isolated Digital Input Module using the DCON and Modbus Protocols (Gray Cover) (RoHS)
M-7053D-G CR	M-7053 with LED Display (Gray Cover) (RoHS)

## Accessories

	tM-7520U CR	RS-232 to RS-485 Converter (RoHS)
	tM-7561 CR	USB to RS-485 Converter (RoHS)
	tM-SG4 CR	RS-485 Bias and Termination Resistor Module (RoHS)
	I-7514U CR	4-channel RS-485 Hub (RoHS)
	SG-770 CR	7-channel Differential or 14-channel Single-ended Surge Protector (RoHS)
	SG-3000 Series	Signal Conditioning Modules for Thermocouple, RTD, DC Voltage, DC Current and Power Input Transformers

2  
3

RS-485 Remote I/O Modules

I-7052/I-7052D/I-7053\_FG/I-7053D\_FG/M-7052/M-7052D/M-7053/M-7053D