

Features

- 7 Digital Input and 8 Digital Output channels
- Open Collector Output
- Non-isolated input for all channels
- Digital Input Channels can be used as 16-bit Counters
- Configurable Power-on Value Settings
- Configurable Safe Value Settings
- Dual Watchdog
- Wide Operating Temperature Range: -25 to +75°C



Introduction

The I-7050 series of modules offers channels for digital input and 8 channels for digital output, each of which are non-isolated. The I-7050 supports sink-type output using an NPN open collector, and source-type input. All input channels are able to be used as 16-bit counters. There are also options to enable both power-on and safe values. The I-7050D has 15 LED indicators that can be used to monitor channel status. The M-7050 has the same hardware specifications as the I-7050, but provides additional support for the Modbus RTU protocol as well as the DCON protocol.

System Specifications

Model	I-7050	I-7050D	I-7050A	I-7050AD
	M-7050	M-7050D		
Communication				
Interface	RS-485			
Bias Resistor	No (Usually supplied by the RS-485 Master. Alternatively, add a tM-SG4 or SG-785.)			
Format	(N, 8, 1) (N, 8, 2) (E, 8, 1) (O, 8, 1)			
Baud Rate	1200 to 115200 bps			
Protocol	DCON (For I-7050 series) Modbus RTU, DCON (For M-7050 series)			
Dual Watchdog	Yes, Module (1.6 Seconds), Communication (Programmable)			
LED Indicators/Display				
System LED Indicator	Yes, 1 as Power/Communication Indicator			
I/O LED Indicators	-	Yes, 7 LEDs as Digital Input and 8 LEDs as Digital Output Indicators	-	Yes, 7 LEDs as Digital Input and 8 LEDs as Digital Output Indicators
7-segment LED Display	-			
Isolation				
Intra-module Isolation, Field-to-Logic	-			
EMS Protection				
ESD (IEC 61000-4-2)	-			
EFT (IEC 61000-4-4)	-			
Surge (IEC 61000-4-5)	-			
Power				
Reverse Polarity Protection	Yes			
Input Range	+10 ~ +30 Vdc			
Consumption	0.4 W 0.4 W	1.1 W 1.1 W	0.5 W	1.2 W
Mechanical				
Dimensions (L x W x H)	123 mm x 72 mm x 35 mm			
Installation	DIN-Rail or Wall Mounting			
Environment				
Operating Temperature	-25 to +75°C			
Storage Temperature	-40 to +85°C			
Humidity	10 to 95% RH, Non-condensing			

Applications

Building Automation, Factory Automation, Machine Automation, Remote Maintenance, Remote Diagnosis, Testing Equipment.

I/O Specifications

Model	I-7050	I-7050D	I-7050A	I-7050AD
	M-7050	M-7050D		
Digital Input/Counter				
Channels	7			
Type	Dry Contact	Sink		
	Wet Contact	Source		Sink
Wet Contact	ON Voltage Level	-		+4 ~ 30 Vdc
	OFF Voltage Level	-		+1 Vdc Max.
Dry Contact	ON Voltage Level	Open		-
	OFF Voltage Level	Close to GND		-
	Effective Distance for Dry Contact	500 m Max.		-
Counters	Max. Count	65535 (16-bit)		
	Max. Input Frequency	100 Hz		
	Min. Pulse Width	5 ms		
Input Impedance	100 kΩ			
Channel-to-Channel Isolation	-			
Overvoltage Protection	-			
Digital Output				
Channels	8			
Type	Open Collector			
Sink/Source (NPN/PNP)	Sink			Source
Load Voltage	+3.5 ~ 30 VDC			
Max. Load Current	30 mA/Channel			50 mA/Channel
Overvoltage Protection	-			
Overload Protection	-			
Power-on Value	Yes			
Safe Value	Yes			

Internal I/O Structure

I-7050(D)/M-7050(D)

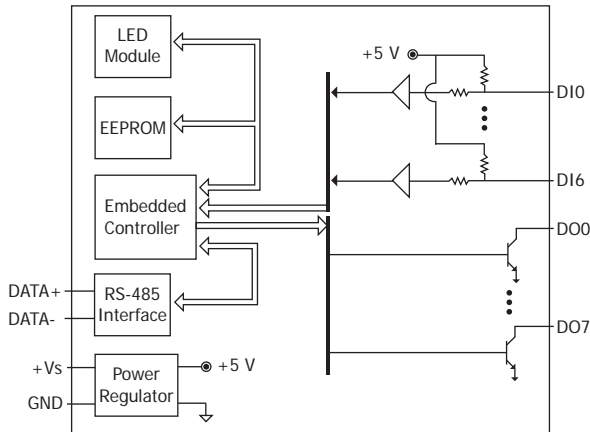

I-7050A/I-7050AD

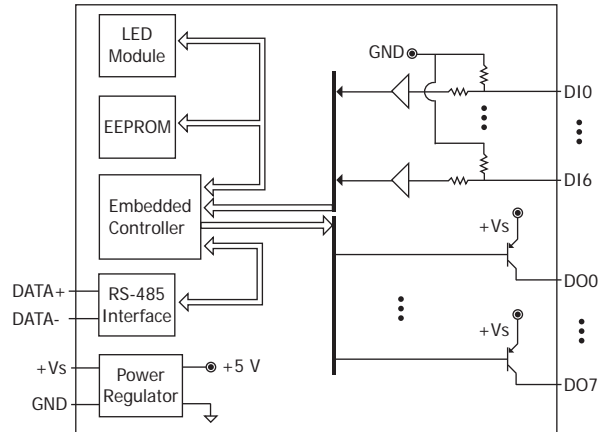

Wire Connections

I-7050(D)/M-7050(D)		
Digital Input/Counter	ON State Readback as 1	OFF State Readback as 0
	Close to GND (+1 VDC Max.)	OPEN (+4 VDC ~ +30 VDC)
Dry Contact		
Output Type	ON State Readback as 1	OFF State Readback as 0
Resistance Load		
Inductance Load		

I-7050A/M-7050AD	
Digital Input	
Digital Output	

Pin Assignments

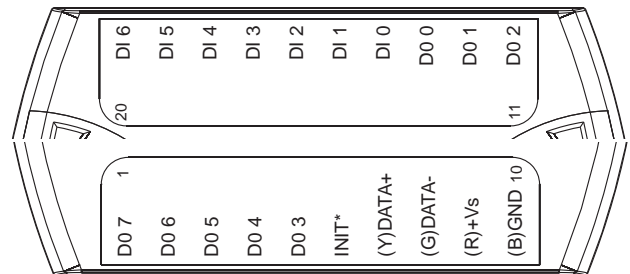

Ordering Information

I-7050 CR	7-channel Non-isolated Digital Input and 8-channel Non-isolated Digital Output Module using the DCON Protocol (Blue Cover) (RoHS)
I-7050-G CR	7-channel Non-isolated Digital Input and 8-channel Non-isolated Digital Output Module using the DCON Protocol (Gray Cover) (RoHS)
I-7050D CR	I-7050 with LED Display (Blue Cover) (RoHS)
I-7050D-G CR	I-7050 with LED Display (Gray Cover) (RoHS)
I-7050A CR	7-channel Non-isolated Digital Input and 8-channel Non-isolated Digital Output Module using the DCON Protocol (Current Sink) (Blue Cover) (RoHS)
I-7050AD CR	I-7050A with LED Display (Blue Cover) (RoHS)
I-7050AD-G CR	I-7050A with LED Display (Gray Cover) (RoHS)
M-7050-G CR	7-channel Non-isolated Digital Input and 8-channel Non-isolated Digital Output Module using the DCON and Modbus Protocol (Gray Cover) (RoHS)
M-7050D-G CR	M-7050 with LED Display (Gray Cover) (RoHS)

Accessories

	tM-7520U CR	RS-232 to RS-485 Converter (RoHS)
	tM-7561 CR	USB to RS-485 Converter (RoHS)
	tM-SG4 CR	RS-485 Bias and Termination Resistor Module (RoHS)

	I-7514U CR	4-channel RS-485 Hub (RoHS)
	SG-770 CR	7-channel Differential or 14-channel Single-ended Surge Protector (RoHS)
	SG-3000 Series	Signal Conditioning Modules for Thermocouple, RTD, DC Voltage, DC Current and Power Input Transformers

2
3

RS-485 Remote I/O Modules

I-7050(D)/I-7050A(D)/M-7050(D)