



DeviceNet Series Products

Modbus TCP Server to DeviceNet Master Gateway



GW-7434D

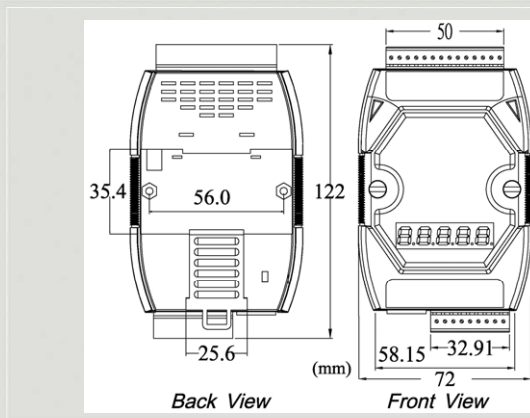

Dimensions

The GW-7434D from ICP DAS is a solution that provides a communication protocol transfer the DeviceNet and Modbus TCP protocol and solves a mission-critical problem: connecting an existing DeviceNet network to Ethernet-based PLCs and PC-based configuration and monitor system. It enables DeviceNet networks to be coupled together over the Internet/Ethernet, whereby remote monitoring and control is possible. The GW-7434D can be a DeviceNet master device in the CAN bus on the DeviceNet network. It supports “Predefined Master/Slave Connection Set” and “Group 2 Only Server” functions to communication with slave devices.

Features

- Supports maximum DeviceNet devices up to 63
- Predefined Master/Slave Connection Set
- Supports one Poll, one Bit-Strobe, one COS or one Cyclic IO connection for each DeviceNet device
- Supports on-line adding device into and removing device from network
- Converts single Modbus TCP to multi Modbus RTU devices, setting by Utility
- Supports VxComm technique for every COM ports of controllers, setting by Utility
- Supports Modbus RTU to DeviceNet master, setting by Utility
- Allows multi-client access simultaneously

Modbus TCP Command Support

Function code.	Description
01 (0x01)	Read Coil Status
02 (0x02)	Read Input Status
03 (0x03)	Read Holding Registers
04 (0x04)	Read input Registers
05 (0x05)	Force Single Coils
06 (0x06)	Preset Single Register
15 (0x0F)	Force Multi Coils
16 (0x10)	Preset Multi Registers

Utility Features

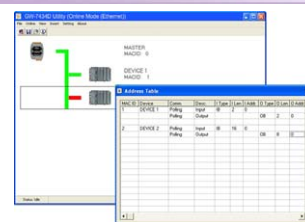

- Online add/remove DeviceNet devices via Ethernet
- Online monitor and configure devices status via Ethernet
- Get/Set Modbus TCP input/output memory address
- Support communication mode setting
- DeviceNet baud and ID configuration

Pin Assignments

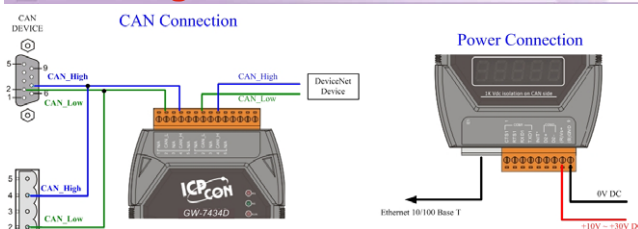

Design Flowchart

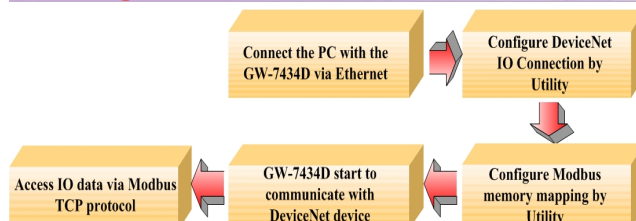

Hardware Specifications

Hardware	
CPU	80186, 80 MHz or compatible
SRAM/Flash/EEPROM	512 KB / 512 KB / 16 KB
Watchdog	Watchdog IC
CAN Interface	
Controller	NXP SJA1000T with 16 MHz clock
Transceiver	NXP 82C250
Connector	5-pin screwed terminal block (CAN_L, CAN_H, N/A for others)
Isolation	1000 V _{DC} for DC-to-DC, 2500 Vrms for photo-couple
Protocol	DeviceNet Volume I ver2.0, Volume II ver2.0
UART Interface	
COM 1	RS-232
COM 1 Connector	5-pin screwed terminal block (TxD, RxD, RTS, CTS, GND)
COM 2	RS-485 (Self-turner inside)
COM 2 Connector	2-pin screwed terminal block (DATA+, DATA-)
Ethernet Interface	
Controller	10/100Base-TX Ethernet Controller (Auto-negotiating, Auto_MDIX)
Connector	RJ-45 with LED indicator
Protocol	Modbus TCP
Power	
Power supply	Unregulated +10 ~ +30 V _{DC}
Protection	Power reverse polarity protection, Over-voltage brown-out protection
Power Consumption	2.5 W
Mechanism	
Dimensions	72mm x 122mm x 33mm (W x L x H)
Environment	
Operating Temp.	-25 ~ 75 °C
Storage Temp.	-30 ~ 80 °C
Humidity	10 ~ 90% RH, non-condensing

Application

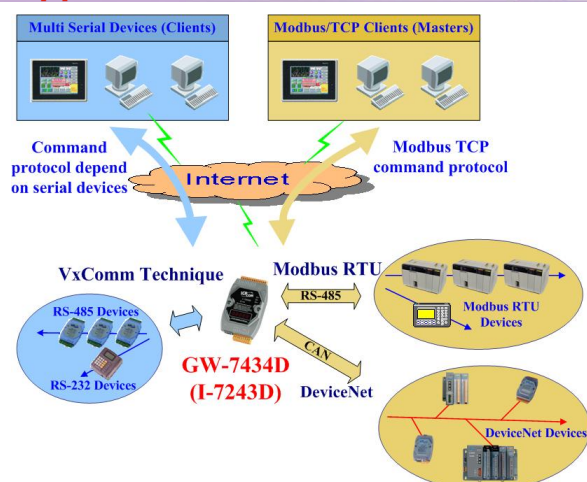

5-digit 7-segment Display

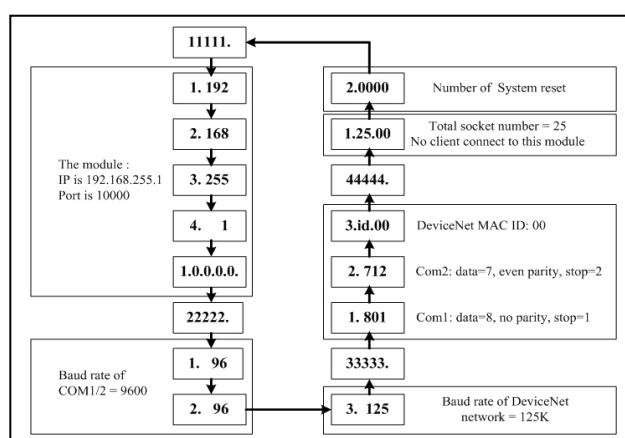

Ordering Information

GW-7434D-G	Modbus TCP server to DeviceNet master Gateway
GW-7434D-G CR	Modbus TCP server to DeviceNet master Gateway (RoHS)